

Contents

Contents	1
1 Out of Box Audit	6
1.1 Inspect the Package.....	6
1.2 Power Connection.....	6
1.3 Fuse.....	6
1.4 Environment.....	7
1.5 Use of Test Fixture.....	7
1.6 Warm-Up.....	7
1.7 Safety Requirements.....	7
1.7.1 Insulation Resistance.....	7
1.7.2 Insulation Intensity.....	8
1.7.3 Leakage Current.....	8
1.8 Electromagnetic Compatibility Requirements.....	8
1.9 Other Features.....	8
2 Introduction	9
2.1 Front Panel.....	9
2.2 Rear Panel.....	11
2.3 Display Areas.....	13
2.4 Main Menu Keys and Their Corresponding Pages.....	13
2.4.1 [DISP].....	13
2.4.2 [SETUP].....	14
2.4.3 [SYSTEM].....	14
2.5 Basic Operation.....	14
2.6 Power ON/OFF.....	14
3 Description of the LCR Function Module	16
3.1 <Meas Display>.....	16
3.1.1 Common Measurement Settings.....	16
3.1.2 Measurement Function.....	17
3.1.3 Decimal Point Position.....	17
3.1.4 Display Results of BIN Sorting.....	18
3.1.5 Save Bridge Measurement Results to USB Flash Drive.....	19
3.2 <List Display>.....	19
3.2.1 Save List Sweep Measurement Results to USB Flash Drive.....	20
3.3 <Trace Display>.....	21
3.3.1 Trigger Mode.....	21
3.3.2 Scale.....	21
3.3.3 Max/Min.....	22
3.3.4 Coordinate Format.....	22
3.3.5 Cursor.....	22
3.3.6 Trace.....	23
3.3.7 Number of Sweep Points.....	23
3.3.8 Save Measurement Results to USB Flash Drive.....	24

3.3.9 Other Measurement Results	25
3.4 <Meas Setup>	26
3.4.1 Measurement Function	26
3.4.2 Frequency	27
3.4.3 Level	27
3.4.4 Speed	28
3.4.5 Range	29
3.4.6 DC Bias	29
3.4.7 Level Monitoring Function	30
3.4.8 Trigger Settings	31
3.4.9 Average	31
3.4.10 Automatic Level Control	32
3.4.11 Internal Resistance	32
3.4.12 Deviation and Reference	32
3.5 <Limit Setup>	33
3.5.1 Comparator Function	34
3.5.2 Comparator Count Function	34
3.5.3 Comparator Function Limit Mode	34
3.5.4 Parameters to Compare	34
3.5.5 Deviations and References	34
3.5.6 Sorting BIN ON/OFF	35
3.5.7 High/Low Limits	35
3.6 <List Setup>	35
3.6.1 Number of Scan Points	36
3.6.2 Trigger Mode	36
3.6.3 List Mode	36
3.6.4 Difference Mode	36
3.6.5 Sweep Condition	37
3.6.6 Parameter Functions	37
3.6.7 High/Low Limits	37
3.6.8 Comparison	37
3.6.9 Delay	38
3.7 <Trace Setup>	38
3.7.1 Common Measurement Settings	38
3.7.2 Sweep Parameters	39
3.7.3 Spilt Screen	39
3.7.4 Number of Scan Points	39
3.7.5 Sweep Type	39
3.7.6 Trace Mode	40
3.7.7 X Format	40
3.7.8 Max/Min	40
3.7.9 Comparison	40
3.8 User Correction	41
3.8.1 Open-Circuit Correction	42
3.8.2 Short-Circuit Correction	43
3.8.3 Load Correction	44

3.8.4 Cable	44
3.8.5 Point Frequency Operation	44
3.9 Handler Settings	45
4 System and File	46
4.1 <System Setup>	46
4.1.1 Mode Setup	46
4.1.2 User Setup	47
4.1.3 RS232 Settings	48
4.1.4 LAN	49
4.1.5 Tools	49
4.2 <File>	51
4.2.1 USB Drive Performance Management	51
4.2.2 Introduction to the Save/Load Function	51
4.2.3 Basic Menu Operations of File Management	52
4.2.4 Operation Steps for File Management (Save/Load)	53
5 Execute LCR Measurement and Some Examples	54
5.1 Corrections	54
5.1.1 Sweep Correction	54
5.1.2 Point-Frequency Correction	54
5.2 Correct Connection of DUT	55
5.3 Eliminate the Influence of Stray Impedance	56
5.4 Example: Testing Inductance	57
5.4.1 Measurement Settings	57
5.4.2 Operation Steps	57
5.5 Example: Testing Capacitance by Multi-Frequency List Sweep	58
5.5.1 Measurement Settings	58
5.5.2 Operation Steps	58
5.6 Example: Load Correction	59
5.6.1 Measurement Settings	59
5.6.2 Operation Steps	59
6 Performance and Test	61
6.1 Measurement Function	61
6.1.1 Parameters	61
6.1.2 Measurement Combination	61
6.1.3 Mathematical Operation	61
6.1.4 Equivalent Mode	61
6.1.5 Range	61
6.1.6 Trigger Mode	62
6.1.7 Delay Time	62
6.1.8 Connection Modes of Test Terminals	62
6.1.9 Measurement Speed (Frequency \geq 10 kHz)	62
6.1.10 Average	62
6.1.11 Digits Displayed	62

6.2 Measurement Signal	63
6.2.1 Measurement Signal Frequency	63
6.2.2 Signal Mode	63
6.2.3 Measurement Signal Level	63
6.2.4 Output Impedance	63
6.2.5 Monitor for Measurement Signal Level	63
6.2.6 Maximum Measurement Display Range	64
6.2.7 DC Bias Voltage Source	64
6.2.8 2A Bias Current Source	64
6.3 Measurement Accuracy	64
6.3.1 Accuracy of $ Z $, $ Y $, L, C, R, X, G, B	65
6.3.2 Accuracy of D	65
6.3.3 Accuracy of Q	65
6.3.4 Accuracy of Θ	66
6.3.5 Accuracy of G	66
6.3.6 Accuracy of R_p	66
6.3.7 Accuracy of R_s	66
6.3.8 Accuracy of DCR	67
6.3.9 Accuracy of Lk	67
6.3.10 Accuracy of Turns Ratio	67
6.3.11 Accuracy Factor	68
6.4 Performance Testing	71
6.4.1 Operating Conditions	71
6.4.2 Used Instruments and Devices	71
6.4.3 Basic Functionality Check	72
6.4.4 Check the Signal Level	72
6.4.5 Check the Frequency	72
6.4.6 Check the Measurement Accuracy	72
7 Command Reference	74
7.1 GPIB Common Commands	74
7.2 SCPI Command	75
7.2.1 DISPlay Subsystem Commands	76
7.2.2 FREQuency Subsystem Commands	77
7.2.3 VOLTage Subsystem Commands	78
7.2.4 CURRent Subsystem Commands	78
7.2.5 AMPLitude Subsystem Commands	79
7.2.6 OUTPut Subsystem Commands	79
7.2.7 BIAS Subsystem Commands	80
7.2.8 TRIGger Subsystem Commands	82
7.2.9 AMPLitude Auto Level Subsystem Commands	84
7.2.10 Output RESister Internal Resistance Subsystem Commands	84
7.2.11 FUNCtion Subsystem Commands	84
7.2.12 COMParator Subsystem Commands	89
7.2.13 LIST Subsystem Commands	92
7.2.14 TRACE Subsystem Commands	102
7.2.15 Handler Subsystem Commands	107

7.2.16 FETCh? Subsystem Commands	109
7.2.17 CORRection Subsystem Commands.....	112
7.2.18 Mass MEMory Subsystem Commands.....	118
7.2.19 SYSTem Subsystem Commands.....	119
7.3 Modbus Commands	125
7.3.1 Write Command Format.....	125
7.3.2 Read Command Format	126
7.3.3 CRC16 Calculation Method – Look-Up Table Method	126
7.3.4 Command Function Comparison Table.....	128
7.4 Examples of Writing Commands	139
7.4.1 Examples of LCR Scan Commands	139
8 Handler Interface Description.....	140
8.1 BIN Sorting.....	140
8.1.1 Technology Description.....	140
8.1.2 Electrical Features	144
8.1.3 Handler Wiring Instructions of BIN Sorting	145
8.1.4 Using Operations	147
8.2 List Sweep.....	148
8.2.1 List Sweep Sorting Logic	148
8.2.2 Technical Description.....	148
8.2.3 Electrical Features	152
8.2.4 Wiring Instructions	152
8.2.5 Using the List Sweep Comparison.....	152

1 Out of Box Audit

Thank you for choosing our product – if you have any questions after reading this manual, please feel free to contact Source-tronic. When you receive the product, some inspections are needed before installation.

Note: This user manual is intended for ST2840A and ST2840B model instruments (summarized as ST2840 when there is no functional difference). Due to the similarities and differences between these and other models, there may still be occasional mentions in the text of information or features that do not apply to your device. These can be disregarded.

1.1 Inspect the Package

After unpacking, you should first check that the instrument has not been damaged in transit. We do not recommend that you turn on the unit if it is damaged.

Then check it against the packing list. If there is any discrepancy, please contact our company or dealer as soon as possible to protect your rights.

1.2 Power Connection

- **Power-Supplying Voltage Range:** 100 ~ 120 V AC or 198 ~ 242 V AC. This depends on the power setup of the rear panel.
- **Power-Supplying Frequency Range:** 47 ~ 63 Hz.
- **Power-Supplying Power Range:** up to 130 VA.
- The power-supplying input phase line L, zero line N, ground lead E must be the same as the power plug of the instrument.
- Although the instrument is able to reduce the interference caused by AC power terminal input, we still recommend it be used in a low-noise environment, or, if this is not possible, with an input filter.

Warning!	
	Make sure the supply line is always reliably grounded; otherwise, leakage may cause injury to the user or damage to the product!

1.3 Fuse

Please use the fuse that is pre-installed in the instrument.

Warning!	
	Make sure the fuse position matches your power supply voltage range!

1.4 Environment

- Please do not operate the instrument in an environment where it will be subjected to strong vibrations, dust, direct sunlight or corrosive air.
- The normal working temperature is 0 °C ~ 40 °C with a relative humidity of $\leq 75\%$, so the instrument should be used under these conditions to guarantee its accuracy.
- There is a heat abstractor on the rear panel to avoid the inner temperature rising – to ensure good ventilation, please do not obstruct the left and right vents.
- Although the instrument is specifically designed to reduce the noise caused by AC power, an environment with low interference is still recommended. If this is not possible, please make sure to use an input filter.
- Please store the instrument at a temperature ranging between 5 °C ~ 40 °C, with a relative humidity of $< 85\%$ RH, and ensure a non-corrosive environment. If the instrument will not be used for a time, please have it properly packed with its original box or a similar box for storing.
- The instrument, especially the test cables, should be kept as far away as possible from any strong electromagnetic field, to avoid interference during measurement.

1.5 Use of Test Fixture

Please only use the included or additionally purchased original cables and test fixture, as **foreign ones may lead to incorrect measurements**. The test fixture or cable should be kept clean, as well as the DUT pin, to ensure a good connection between the DUT and fixture.

Connect the fixture or cables to the four test terminals **Hcur**, **Hpot**, **Lcur**, **Lpot** on the front panel. For a DUT with shielding, connect it to the ground connection \perp .

Note: If neither test fixture nor cables have been connected, the instrument will display an unstable measurement result.

1.6 Warm-Up

- 1) To guarantee an accurate measurement, the instrument should be given a warm-up time of no less than 30 minutes.
- 2) Please do not switch the instrument on and off unnecessarily; this may affect measurement accuracy.

1.7 Safety Requirements

The devices of the ST2840 series correspond to protection class I.

1.7.1 Insulation Resistance

Under normal operating conditions, the insulation resistance between the power terminal and the device housing must not be less than 50 M Ω .

In case of increased humidity, the insulation resistance between the voltage terminal and the device housing must not be less than 2 M Ω .

1.7.2 Insulation Intensity

Under normal operating conditions, the device can withstand a voltage of 1.5 kV AC 50 Hz between the mains connection and the device housing for at least 1 minute without voltage drop or flashover.

1.7.3 Leakage Current

The leakage current should not exceed 3.5 mA (AC effective value).

1.8 Electromagnetic Compatibility Requirements

According to Directive 2006/95/EC safety requirements

EN 61010-1:2010+A1:2019 Safety requirements for electrical equipment for measurement, control and laboratory use.

According to Directive 2004/108/EC on electromagnetic compatibility

EN 61326-1:2021 Electromagnetic compatibility requirements for electrical equipment for measurement, control and laboratory use.

- CISPR 11:2015+A1:2016+A2:2019 Radiated and conducted emissions, Group 1, Class A
- EN 61000-4-2:2009 Electrostatic discharge immunity
- EN 61000-4-3:2020 Radiated, radio frequency, electromagnetic field immunity
- EN 61000-4-4:2012 Electrical fast transient/burst immunity
- EN 61000-4-5:2014+A1:2017 Surge immunity for power supply lines
- EN 61000-4-6:2014 Conducted radio frequency immunity
- EN 61000-4-11:2020 Voltage dips and interruptions immunity

EN 61000-3-2:2019+A1:2021 Harmonic emission for AC power supply lines

EN 61000-3-3:2013+A1:2019+A2:2021 Voltage variations, fluctuations and flicker

1.9 Other Features

Dimensions (W × H × D): 430 mm × 177 mm × 265 mm

Weight: approx. 11 kg

2 Introduction

This chapter details the basic operation features of ST2840A/B Precision LCR Meters. Please read this chapter carefully before using your device.

2.1 Front Panel

Figure 2-1 shows the front panel of ST2840A/B instruments.

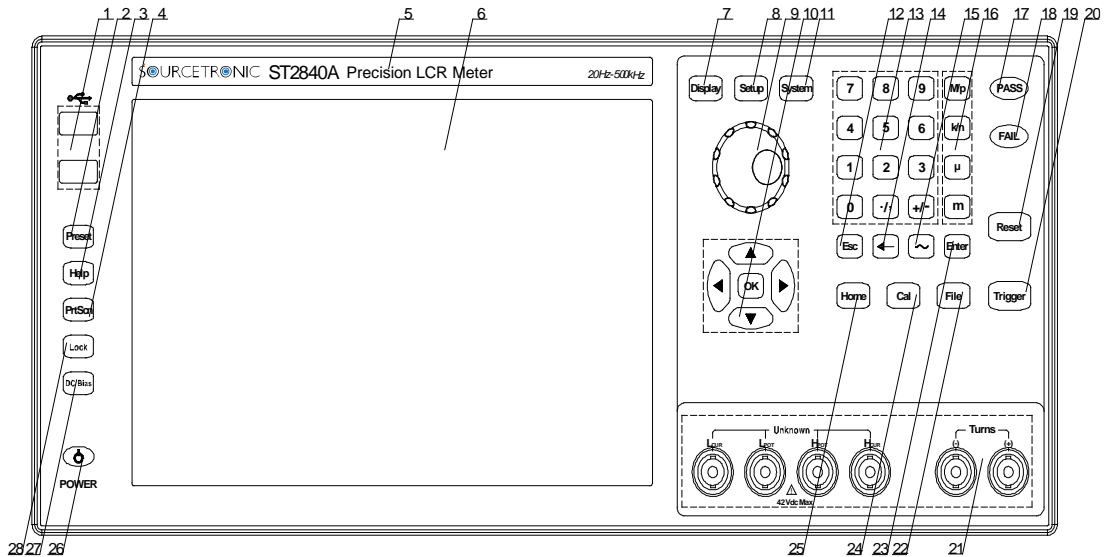

Figure 2-1 Front Panel

1) USB Host Interface

ST2840 is equipped with two USB host interfaces, which can be used to connect USB storage to save and load files from, or to connect to devices such as a mouse, keyboard, or scanner. Note that only one USB storage device can be inserted at a time.

2) [PRESET]

Press this key to restore the instrument to its factory default settings.

3) [HELP]

Upon pressing this key it lights up, and the display will pop up information and operation instructions regarding the element the cursor is located at. If you press the same key again, the light will go out, and the pop-up window will close.

4) [PRTSCN]

Press this key to save a screenshot of the current interface to the inserted USB device.

5) Brand and Model

Details the brand and model number.

6) LCD Liquid Crystal Display

1280x800 color LCD capacitive touch screen, showing the measurement results and settings.

7) [DISP]

Press this key to enter the measurement display page of the corresponding function (bridge, focus scan).

8) [SETUP]

Press this key to enter the measurement settings page of the corresponding function (bridge).

9) Knob with Confirmation Function

Move the cursor, select and set parameters. The button in the middle is used to conclude data input and confirm.

10) Cursor Keys and [OK] Key

The cursor keys are composed of up (↑), down (↓), left (←) and right (→), which are used to move the cursor between different areas on the LCD display page. When the cursor moves to a certain area, that area will be highlighted on the LCD screen. The middle of the cursor keys is the [OK] key; its function is similar to the [ENTER] key.

11) [SYSTEM]

Press this key to access the system setup page.

12) [ESC]

"Escape" key.

13) Numeric Keys

The numeric keys are composed of the digits [0] to [9], a decimal point [./] and [+/-] keys; they are used to input data directly.

14) [←]

Backspace key. Press this key to delete the last digit of the entered value.

15) [~]

This key is required for functions that are not relevant to ST2840A/B model instruments.

16) Magnitude Key

Press this key to input the magnitude of the corresponding parameter.

17) PASS Indicator

LED indicator that shows the measurement has concluded successfully.

18) FAIL Indicator

LED indicator that shows the measurement has failed.

19) [RESET]

While in a list scan or trace scan of the bridge, press this key to pause the scan, and press the [TRIGGER] key to continue the scan from where it previously paused.

20) [TRIGGER]

When the trigger mode is set to single mode, press this key to start a measurement cycle.

21) Test Terminals (UNKNOWN)

Four-terminal test pairs are used to connect a four-terminal test fixture or cable to the DUT. The terminals are as follows:

- Hcur
- Hpot
- Lpot
- Lcur

22) [FILE]

Press this key to access the <File Manage> page.

23) [ENTER]

Press this key to conclude data input, confirm, and save the data currently displayed in the input line.

24) [CAL]

Shortcut keys to perform user calibrations.

25) [HOME]

Press this key to switch between the instrument's different functions.

26) POWER Switch

The button is lit up in red while in standby mode and green while powered on. To shut down the instrument, press and hold the power switch.

27) [DC BIAS]

This key is used to enable or disable the output of 0 ~ 100 mA, ± 40 V, 0 ~ 2 A DC bias source. If you press this key, it will light up, indicating that the DC bias output is enabled; if you press the same key again, the light will go out, indicating that the DC bias output is now disabled. In some non-measurement screens where DC bias cannot be applied, pressing this button will have no response.

28) [LOCK]

If you press this key, it will light up, indicating that the key functions of the current panel are locked; if you press the same key again, the light will go out, indicating that the keyboard lock state is released. If the password function is set to ON, the correct password must first be entered when unlocking the keyboard. When the instrument is controlled by RS232, USB_Device, LAN port, etc., the [LOCK] button is also active and lit up. In this case, too, you can unlock by pressing [LOCK] again.

2.2 Rear Panel

Figure 2-2 briefly describes the rear panel of ST2840A/B instruments.

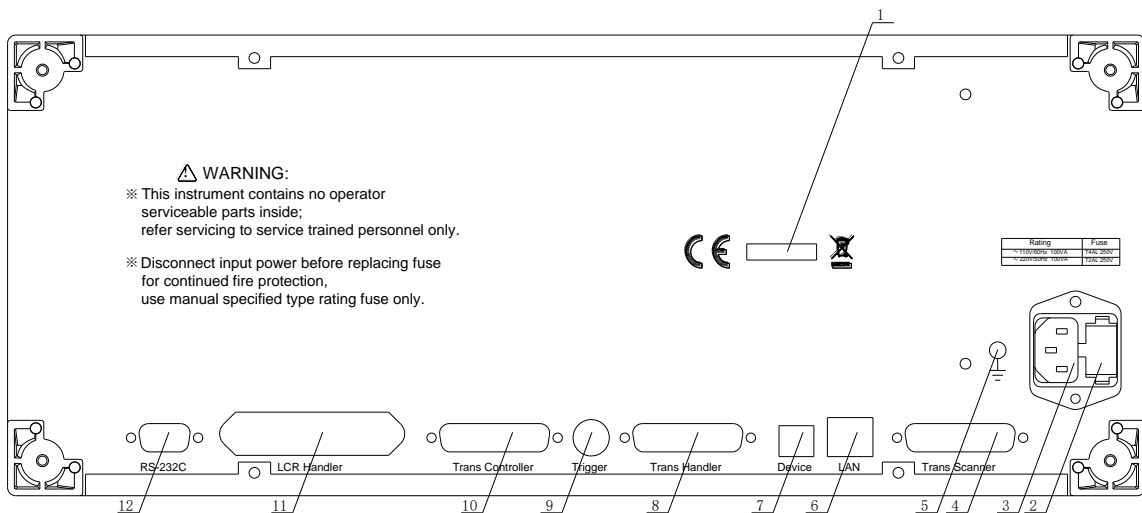

Figure 2-2 Rear Panel

1) Nameplate

Contains information regarding production date, instrument number, manufacturer, etc.

2) Fuse Base

This is used to install a power fuse, protect the instrument, and switch 110 V/220 V by changing the core's direction.

3) Power Socket

Input AC power.

Warning!

Before connecting, make sure that the position of the fuse corresponds to the supply voltage used!

4) TransScanner Interface

This interface is not relevant to ST2840A/B model instruments.

5) Ground Terminal

This terminal is connected to the chassis of the instrument. It can be used to protect or shield ground connections.

6) LAN Interface

The LAN interface is used to control and communicate within network systems.

7) USB Device Interface

The USB device interface can be used to communicate with the PC.

8) TransHandler Interface

This interface is not relevant to ST2840A/B model instruments.

9) Trigger Interface

External trigger devices such as foot control can be connected here.

10) TransController Interface

This interface is not relevant to ST2840A/B model instruments.

11) LCR Handler Interface

The Handler interface can realize the organized output of measurement results. This interface is used to sort the results of single-group measurements.

12) RS232C Serial Interface

The serial communication interface is used for online communication with the computer.

2.3 Display Areas

ST2840 series instruments use a 10.1-inch capacitive touch screen; the content displayed on the screen is divided into the following display areas:

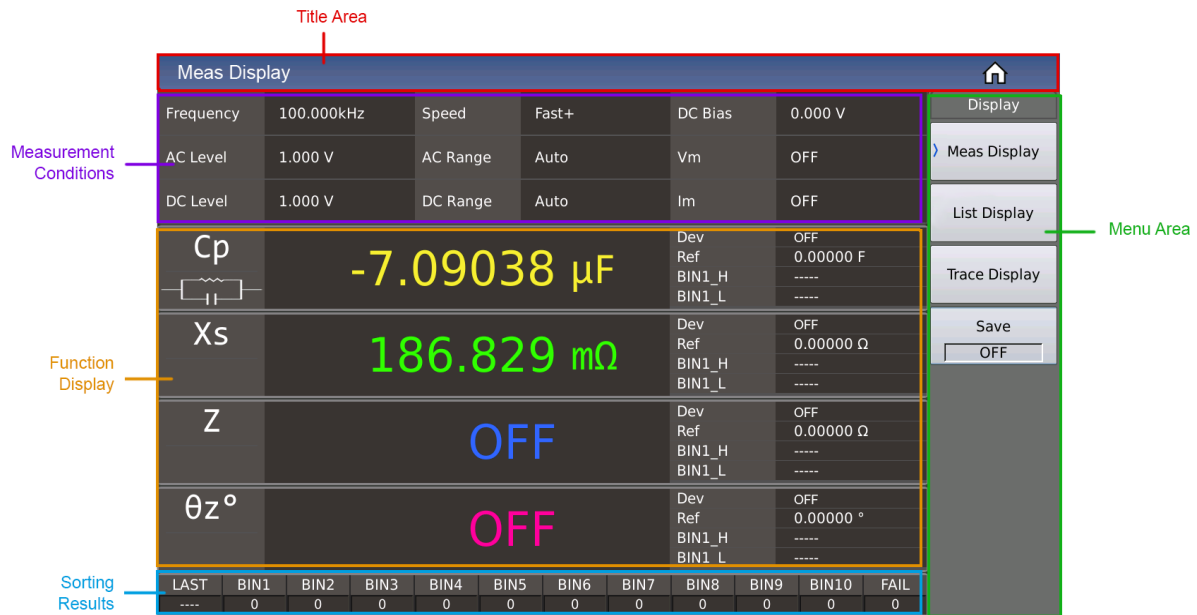

Figure 2-3 Display Areas

The elements shown on this page include:

- Title
- Measurement Conditions (Settings)
- Four-Parameter (Function) Result Display
- Sorting Results
- Menu

2.4 Main Menu Keys and Their Corresponding Pages

2.4.1 [DISP]

When the LCR function is active, press this key to access the LCR measurement display page. Use the touch screen to select from the following function pages:

- **<Meas Display>**
- **<List Display>**
- **<Trace Display >**
- **<Save>**

2.4.2 [SETUP]

When the bridge function is active, press this key to access the setting screen of the component test. The following function pages are available here:

- <Meas Setup>
- <Limit Setup>
- <List Setup>
- <Trace Setup>
- <User Corr>
- <Handler>
- <Tools>

2.4.3 [SYSTEM]

Press this key to enter the system settings homepage, which concerns communication settings, user management settings, and Handler settings. The following function pages are available here:

- <System Info>
- <Message>
- <System Check>
- <License>

2.5 Basic Operation

The basic operation principles of ST2840 series instruments are as follows:

- 1) Use the menu keys ([DISP], [SETUP], [SYSTEM]) and soft keys to select pages.
- 2) Use the cursor keys ([←][→][↑][↓]), knob or directly touch the screen to move the cursor between areas on the screen. When the cursor moves to a certain area, that area will be highlighted. This is where you can now configure settings.
- 3) The soft key functions corresponding to the area the cursor is currently located in will be displayed in the soft key area of the screen. Press the desired soft key to select it. The numeric keys, [←], magnitude keys and the [ENTER] key are used for data input. After pressing a numeric key, you can press the confirmation key or [ENTER] to conclude the data input.

2.6 Power ON/OFF

Plug in the three-wire power supply.

Caution!	
	Keep the power-supply voltage and frequency conform to above specifications. Power input phase line L, zero line N, ground line E should be the same as that of the instrument!

ST2840 series instruments use soft switches.

After plugging in the three-wire power supply, some indicators on the front panel flash briefly. After a few seconds, the power button lights up red, and any other buttons with LED indications go out.

- **Power On:** Press the power switch in the lower left corner of the front panel to turn on the instrument and display the startup screen. Once the instrument is started, the power button lights up green. The power button of ST2840 series instruments has a memory function.
- **Power Off:** If needed, press and hold the power button in the lower left corner of the front panel to turn off the instrument. Upon doing so, the power button lights up red, and the instrument enters standby mode. If you are planning not to use the instrument for an extended period of time, please disconnect the power cord and store the instrument in an appropriate environment as described in chapter 0.

Note: This product series comes with a pre-set default password, which is **2840**. You can of course change the password according to your own needs. For details, please refer to chapter 4.1.2.5 of this user manual.

3 Description of the LCR Function Module

3.1 <Meas Display>

When the LCR function is active, press [DISP] to access the <Meas Display> page, as shown in the following figure:

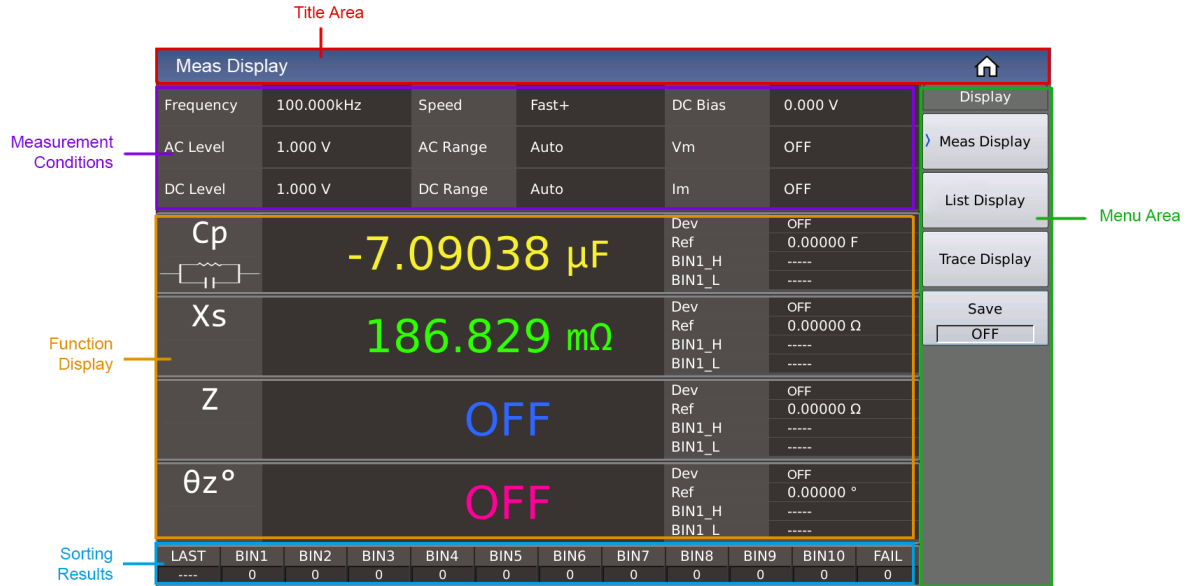

The elements shown on this page include:

- Title
- Measurement Conditions (Settings)
- Four-Parameter (Function) Result Display
- Sorting Results
- Menu
- Status Bar

3.1.1 Common Measurement Settings

There are 9 cursor areas in the measurement settings area of this display page, namely:

- Frequency
- Speed
- DC Bias,
- AC Level
- AC Range
- Vm
- DC Level
- DC Range
- Im

Each of these settings will be described in further detail in the <Meas Setup> chapter of this user manual.

3.1.2 Measurement Function

Touch the position of the parameter name in the measurement result area, and you can see the selection menu of the corresponding measurement function in the right menu area. Touch the corresponding selection area of the menu to complete setting the specified parameter.

The menu display is shown in the following figure:

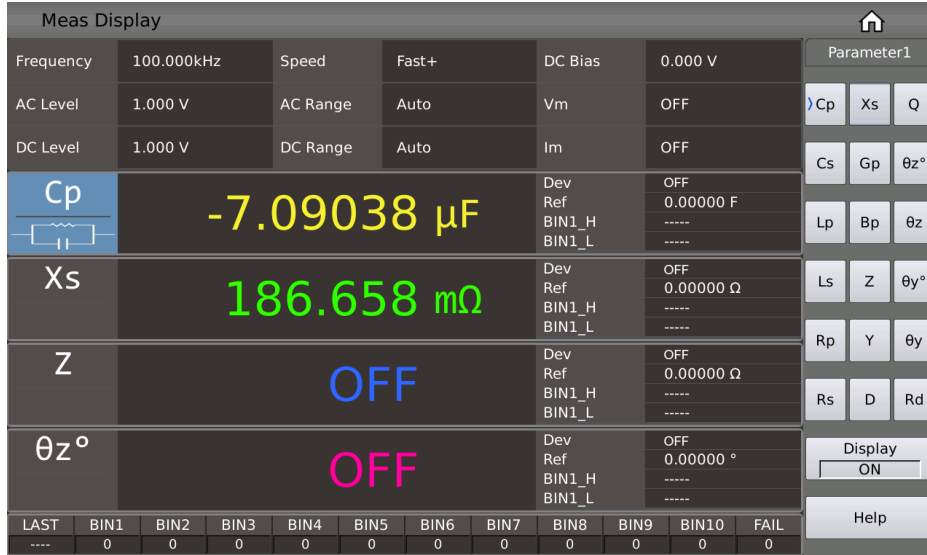

Figure 3-1 Parameter Function Setting

3.1.3 Decimal Point Position

The position of the decimal point has a direct relationship with the resolution of the result displayed; this way, the relative stability of the result can also be seen intuitively.

The principle of moving the position is to ensure that the number of digits remains unchanged, with a certain decimal point on the left and right, as shown in the following figure:

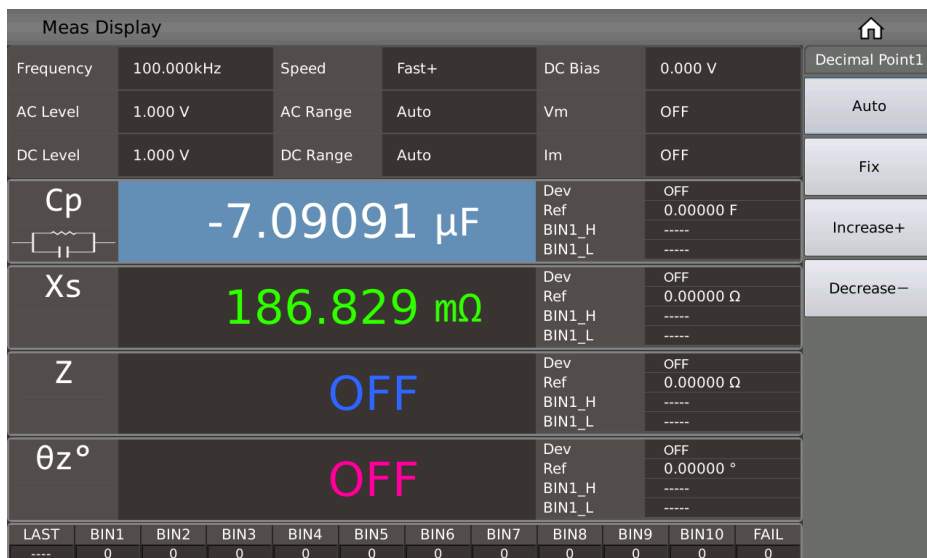

Figure 3-2 Moving the Decimal Point

Parameter Type: select from list

- **AUTO:** The default setting, which automatically adjusts the position of the decimal point.
- **FIX:** Lock the current decimal point position while otherwise in auto mode.

- **Increase (+):** Move the decimal point to the left.
- **Decrease (-):** Move the decimal point to the right.

Note: In the following cases, the decimal point position lock function will be automatically cancelled and restored to the floating decimal point display state:

- The measurement function is changed;
- The deviation mode is changed.

3.1.4 Display Results of BIN Sorting

After touching or moving the cursor to the field that displays sorting results, the corresponding menu will offer some settings for the sorting, such as turning on/off the comparison and counting function, or resetting the count; as shown in the following figure:

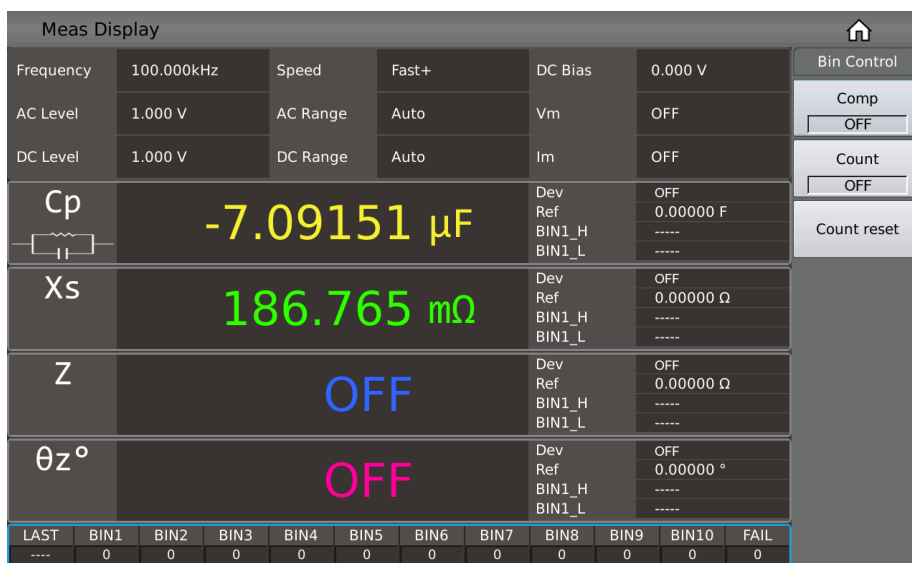

Figure 3-3 Quick Settings for BIN Sorting

3.1.4.1 Comparison Function

ST2840 series instruments come with a built-in comparison function that allows the DUT to be assigned to one of up to eleven sorting bins (BIN1 to BIN10 and BIN OUT). Ten sets of upper and lower limits can be set, and the upper and lower limits of each file containing four parameters can be set independently.

If one or more parameters are not to be included in the comparison, the corresponding upper and lower limits can be cleared.

If the parameters of the DUT that are included in the comparison are all within the range of the BIN limit, the corresponding BIN is found. The results can be output to the automatic test system via the Handler Interface.

These limit settings can only be configured on the <Limit Setup> page.

Parameter Type: ON/OFF; the default setting is OFF.

3.1.4.2 BIN Count Function

This function is used to record and display the count value of each BIN.

Parameter Type: ON/OFF; the default setting is OFF.

3.1.4.3 Count Reset

Restart counting by clearing the count value of the current BIN, so that the BIN count is reset to 0.

3.1.5 Save Bridge Measurement Results to USB Flash Drive

Use the USB flash drive to save the bridge measurement results. The results/settings that can be saved include the following:

- Time
- P1
- P2
- P3
- P4
- BIN

(These correspond, in order, to the test time, parameter 1 ~ 4 result, BIN result.)

The operation steps to save your data are as follows:

- 1) Choose [Save]
- 2) "Save path" prompt; default path location: "usb/CSV/" path
- 3) The naming rule of the file name is rx+machine number+date, such as: rx-SN12345678-20210811.csv

3.2 <List Display>

On the <List Display> page, you can enter up to 201 points of measurement frequency, as well as measurement level, DC bias, trigger delay, independent functions corresponding to four parameters, four independent parameters, and upper and lower limits for each list sweep measurement point. These measurement points will be automatically scanned and measured, and the measurement results will be compared with their respective limit values.

During the list sweep measurement cycle, the leftmost symbol * indicates the current sweep measurement point.

Pt	Freq	Level	Bias	Para1	Para2	Para3	Para4	P/F
1	1.00000kHz	1.00000 V	0.00000 A	Cp=-22.9015pF	Cp=-22.9015pF	Cp=-22.9015pF	Cp=-22.9015pF	---
2	1.00000kHz	1.00000 V	0.00000 A	Cp=-22.9015pF	Cp=-22.9015pF	Cp=-22.9015pF	Cp=-22.9015pF	---
3	1.00000kHz	1.00000 V	0.00000 A	Cp=-22.9015pF	Cp=-22.9015pF	Cp=-22.9015pF	Cp=-22.9015pF	---
4	1.00000kHz	1.00000 V	0.00000 A	Cp=-22.9015pF	Cp=-22.9015pF	Cp=-22.9015pF	Cp=-22.9015pF	---
5	1.00000kHz	1.00000 V	0.00000 A	Cp=-22.9015pF	Cp=-22.9015pF	Cp=-22.9015pF	Cp=-22.9015pF	---
6	1.00000kHz	1.00000 V	0.00000 A	Cp=-22.9015pF	Cp=-22.9015pF	Cp=-22.9015pF	Cp=-22.9015pF	---
7	1.00000kHz	1.00000 V	0.00000 A	Cp=-22.9015pF	Cp=-22.9015pF	Cp=-22.9015pF	Cp=-22.9015pF	---
*8	1.00000kHz	1.00000 V	0.00000 A	Cp=-22.9015pF	Cp=-22.9015pF	Cp=-22.9015pF	Cp=-22.9015pF	---

Figure 3-4 List Display

The P/F on the far right (representing PASS/FAIL) is used to indicate the comparison result of the current point:

- No Comparison Display: "---"

- Comparison successfully completed: PASS (green)
- Comparison failed: FAIL (red)

When the difference mode is active, the measurement results of parameters 3 and 4 are not displayed, and the difference calculation result of parameter 1 is displayed, as shown in the following figure:

Pt	Freq	Level	Bias	Para1	Para2	Delta	P/F
1	1.00000kHz	1.000 V	0.000 V				
2	1.00000kHz	1.000 V	0.000 V				
3	1.00000kHz	1.000 V	0.000 V				
4	1.00000kHz	1.000 V	0.000 V				
5	1.00000kHz	1.000 V	0.000 V				
6	1.00000kHz	1.000 V	0.000 V				
7	1.00000kHz	1.000 V	0.000 V				
8	1.00000kHz	1.000 V	0.000 V				

Figure 3-5 List Display Difference Mode

3.2.1 Save List Sweep Measurement Results to USB Flash Drive

Use the USB flash drive to save the measurement results. The results/settings that can be saved are as follows:

- Time
- pt
- para1 ~ 4
- P1
- P2
- P3
- P4
- COMP

(These correspond, in order, to test time, point index, 4 parameter function, parameter 1 ~ 4 result, comparison result.)

The operation steps to save your data are as follows:

- 1) Choose [Save]
- 2) "Save path" prompt; default path location: "usb/CSV/" path
- 3) The naming rule of the file name is list+machine number+date, such as: list-SN12345678-20210811.csv

3.3 <Trace Display>

Press the menu key [DISP], and then press the soft key [Trace Display] to enter the <Trace Display> page.

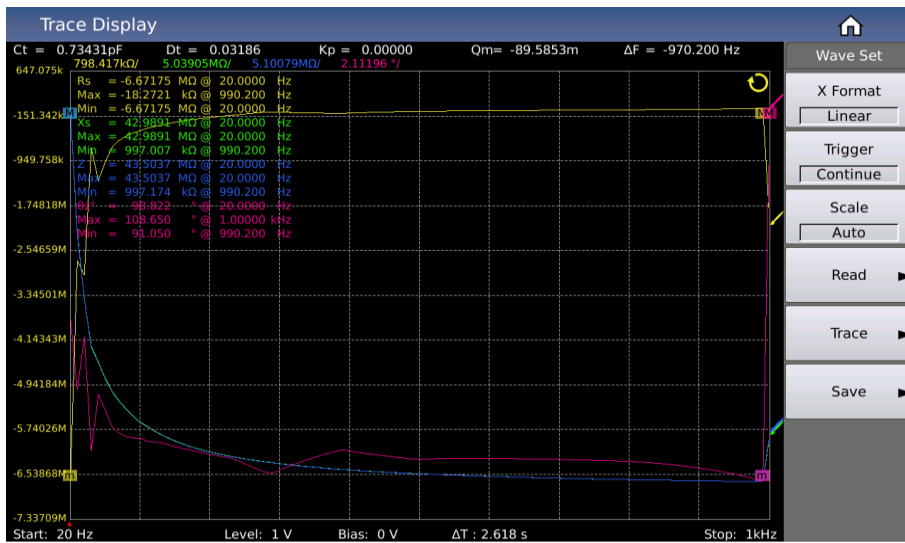

Figure 3-6 Trace Display

On this page, each scan will perform automatic measurement of the component under test at 51, 101, 201, 401 or 801 frequency points, in a linear or logarithmic manner and with increasing conditions within the user preset mode range. The instrument displays a dynamic response curve of the main and secondary parameters of the component under test with changes of the mode conditions on the LCD screen.

The result of any point within the scanning range can be read on the screen. Simultaneously, the maximum and minimum measurement values and corresponding measurement settings within the scan range will be displayed.

Note: After you have configured the scan settings, you must press the [TRIGGER] key on the front panel to begin the scan. Press the [RESET] key once to pause the measurement, and press it again to reset and rescan.

3.3.1 Trigger Mode

This setting is used to define the trigger mode of the curve; please refer to the corresponding section in the <Meas Setup> chapter for details.

3.3.2 Scale

This setting is used to automatically define the Y-axis coordinate range corresponding to the curve. When it's set to AUTO mode, the Y-axis scale range will be dynamically adjusted with the size range of the measurement result to ensure that the drawn curve is within the display range.

It is recommended that when the DUT is relatively stable, you let the scale automatically select a relatively suitable scale range, and then choose FIX to lock it in. Then you can manually press the up and down direction keys to fine-tune the display range according to your own requirements.

Parameter Type: select from list + manual input

- **AUTO:** The scale will adjust automatically.
- **FIX:** The scale is fixed (i.e. will not change on its own), but can still be adjusted manually.

3.3.3 Max/Min

See section 3.7.8.

3.3.4 Coordinate Format

You can set the format of the abscissa and ordinate of parameters 1 to 4 separately, linear or logarithmic. See section 3.7.7.

3.3.5 Cursor

This setting is used to configure the behavior of the cursor (displayed as a red line) on the screen. You can view the measurement results of different parameters under the same scanning condition by turning the knob or using the left and right keys.



Figure 3-7 Cursor Display Effect

Setting Options:

Setting	Description
OFF	Cursor is not displayed.
Manual	Manually adjust the cursor (knob; left and right keys).
Para1Min	Automatically track the minimum or maximum value position of parameter 1/2/3/4.
Para1Max	
Para2Min	
Para2Max	
Para3Min	
Para3Max	
Para4Min	
Para4Max	

3.3.6 Trace

Via the submenu of the curve button, you can quickly choose the sweep points of the curve, whether to hide or show the parameter on the curve for each of the four parameters, how to split the screen between multiple curves, as well as other related settings.

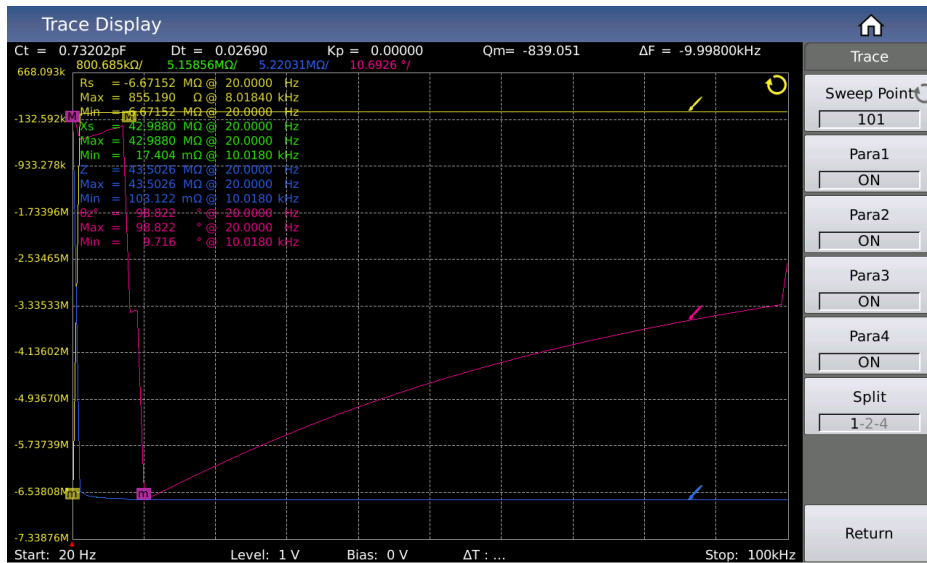

Figure 3-8 Curve Settings Menu

3.3.7 Number of Sweep Points

This setting defines the number of points the instrument scans within the start and end conditions. The system lets you choose the number of measurement points between five settings: 51, 101, 201, 401, and 801. The more scan points you select, the more precise the image will be drawn, but the scan will also take longer. The system default setting is **201**.

3.3.7.1 Parameters 1~4 ON/OFF

These ON/OFF switches are used to include or not include the specified parameter in the displayed curve.

3.3.7.2 Split

This setting lets you choose how to divide the screen to display multiple curves, or not to divide it at all.

Parameter Type: select from list

- **1-Split / None:** All curves are displayed in the same drawing window.
- **2-Split:** Four parameters are grouped in pairs and displayed in two drawing windows.
- **4-Split:** Four parameters are all displayed independently in their own separate drawing windows.

Figure 3-9 showcases what the 2-split screen effect looks like, and Figure 3-10 shows the 4-split screen effect.



Figure 3-9 Display Effect of 2-Split Screen

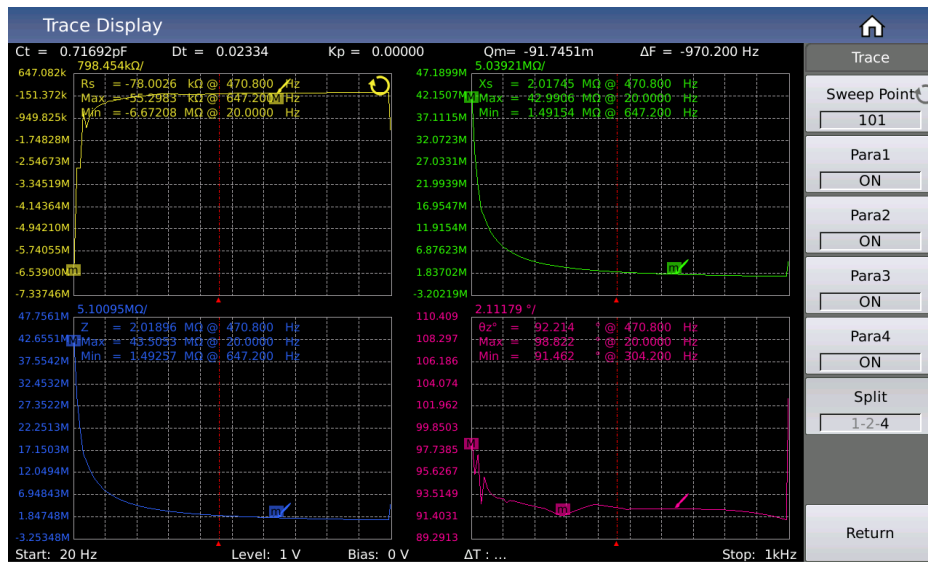

Figure 3-10 Display Effect of 4-Split Screen

3.3.8 Save Measurement Results to USB Flash Drive

Use the USB flash drive to save the test results and curve settings. The results/settings that can be saved are as follows:

- Time
- pt
- x
- P1
- P2
- P3
- P4
- COMP

(These correspond, in order, to test time, point index, x-axis size, parameter 1 ~ 4 result.)

The operation steps to save your data are as follows:

- 1) Choose [Save]
- 2) "Save path" prompt; default path location: "usb/CSV/" path
- 3) The naming rule of the file name is rx+machine number+date, such as: trace-SN12345678-20210811.csv

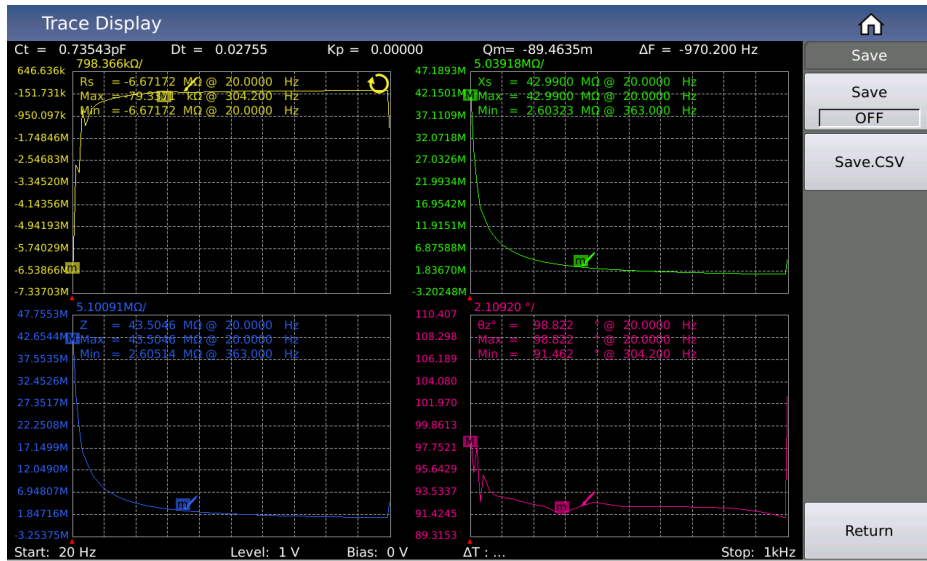

Figure 3-11 Save Settings Menu

Choose whether to continuously save the measurement result data:

- When set to continuous saving, the naming rule of the file name is trace + machine number + date, such as: trace-SN12345678-20210811.csv
- For a single save, the naming rule of the file name is trace-trg + machine number + date, such as: trace-trg-SN12345678-20210811.csv

3.3.9 Other Measurement Results

When you select the scan parameters to be frequency and impedance, the instrument will automatically display some specific parameters of the ultrasonic device. These parameters are as follows:

- Static Capacitance C_t : static capacitance value at 1 kHz.
- Static Capacitance D_t : the capacitance loss value at 1 kHz.
- The minimum impedance Z_{min} and its corresponding frequency f_s , (point m on the screen).
- The maximum impedance Z_{max} and its corresponding frequency f_p , (point M on the screen).

$$\Delta F = f_p - f_s$$

$$k_p \approx \sqrt{\frac{f_p - f_s}{f_s}} \times 2.51$$

$$Q_m \approx \frac{f_p^2}{2\pi f_s Z_{min} C^T (f_p^2 - f_s^2)}$$

3.4 <Meas Setup>

Press [SETUP] to access the <Meas Setup> page as shown below:

Meas Setup						Setup
Frequency	1.0000kHz	Speed	Fast	DC Bias	0.000 V	Meas Setup
AC Level	1.000 V	AC Range	Auto	Vm	OFF	Limit Setup
DC Level	1.000 V	DC Range	Auto	Im	OFF	List Setup
Trigger Mode	Single	Average	1	DCI Iso	OFF	Trace Setup
Trigger Delay	0 s	ALC	OFF	Bias Polarity	Auto	User Corr
Step Delay	0 s	Rsou	100Ω	Bias Source	100mA(40V)	Handler
Parameter1	Rs	Deviation1	OFF	Reference1	0.00000 Ω	
Parameter2	Xs	Deviation2	OFF	Reference2	0.00000 Ω	
Parameter3	Z	Deviation3	OFF	Reference3	0.00000 Ω	
Parameter4	θz°	Deviation4	OFF	Reference4	0.00000 °	

Figure 3-12 Measurement Setup Page

3.4.1 Measurement Function

Parameter Type: select from list

The four parameters of the impedance element can be measured at the same time in one measurement cycle. The measurable parameters are as follows:

Parameter Name	Parameter Meaning	Parameter Name	Parameter Meaning
Cp	Equivalent Parallel Capacitance	Cs	Equivalent Series Capacitance
Lp	Equivalent Parallel Inductance	Ls	Equivalent Series Inductance
Rp	Equivalent Parallel Resistance	Rs	Equivalent Series Resistance
Gp	Conductance	Bp	Susceptance
Z	Absolute Value of Impedance	Y	Absolute Value of Admittance
D	Loss Factor	Q	Quality Factor
θz°	Impedance Degree	θz	Impedance Radian
θy°	Admittance Degree	θy	Admittance Radian
X	Reactance	Rd	DC Resistance

Operation Steps to Set the Measurement Function Parameters:

Touch (or use the cursor keys to move the cursor to) the parameter name area corresponding to the measurement result, and select the setting in the soft key area on the right according to the displayed optional parameters.

There is no restriction on the combination of the four parameters, meaning you can choose whichever combination you want.

The display status of the four parameters can each be set independently, that is, when any parameter's display switch is turned off, that parameter's corresponding area on the screen will simply display OFF instead of a measurement result. This function to turn on/off the parameter display can be set in the parameter setting area on the measurement display page.

3.4.2 Frequency

Parameter Type: numeric input

The maximum range of the measurement frequency depends on instrument model, and the minimum resolution is 0.0001 Hz.

Note: The specific models have different frequency ranges they support:

- **ST2840A:** 20 Hz ~ 500 kHz
- **ST2840B:** 20 Hz ~ 2 MHz

Frequency Range and Measurement Frequency Point:

Frequency Range (f)	Measurement Frequency Point	Resolution
$20 \text{ Hz} \leq f \leq 99.999 \text{ Hz}$	20.0000 Hz, 20.0001 Hz [...] 99.9999 Hz	0.0001 Hz
$100 \text{ Hz} \leq f \leq 999.9 \text{ Hz}$	100.000 Hz, 100.001 Hz [...] 999.999 Hz	0.001 Hz
$1 \text{ kHz} \leq f \leq 9.999 \text{ kHz}$	1.0000 kHz, 1.00001 kHz [...] 9.99999 kHz	0.01 Hz
$10 \text{ kHz} \leq f \leq 99.99 \text{ kHz}$	10.0000 kHz, 10.0001 kHz [...] 99.9999 kHz	0.1 Hz
$100 \text{ kHz} \leq f \leq 999.9 \text{ kHz}$	100.000 kHz, 100.001 kHz [...] 1 MHz	1 Hz
$1 \text{ MHz} \leq f \leq 2 \text{ MHz}$	1.00000 MHz, 1.00001 MHz [...] 2 MHz	10 Hz

Operation Steps to Set the Measurement Frequency:

Directly touch or use the arrow keys to move the cursor to the frequency field. There are two methods to set the frequency:

- Use the number keys to directly input a specific value;
- Use the soft keys (according to the given prompts) to increase/decrease the frequency until you reach the desired value.

3.4.3 Level

The measurement level is divided into AC level and DC level.

- AC level is mainly used for AC LCR measurements.
- DC level is mainly used for DC resistance measurements.

3.4.3.1 AC Level

Parameter Type: numeric input

The measurement level is defined by the effective value of the measurement sine wave signal. The frequency of the sine wave signal is the measurement frequency, which is generated by the internal oscillator of the instrument. You can set either the voltage value or the current value.

Voltage Level Range: 5 mV ~ 20 V

Current Level Range: 50 μ A ~ 100 mA

Note: There is a linear constraint relationship of internal resistance between the voltage level and the current level. (For example, the current level corresponding to 30 Ω internal resistance is 166.7 μ A ~ 66.67 mA, and the current level corresponding to 100 Ω internal resistance is 50 μ A ~ 100 mA).

When the measurement function is set to DCR, 30 Ω or 100 Ω can be selected as the signal source output impedance.

Voltage Level and Resolution:

Voltage Level (V_{rms})	Resolution
[5 m, 1)	1 mV
[1, 20]	10 mV _{rms}

Note: The set measurement current is the output current value when the measured terminal is short-circuited. The set measurement voltage is the output voltage value when the measured terminal is open.

The automatic level control (ALC) function can realize constant voltage or current measurement; it can be enabled on the <Meas Setup> page. When the ALC function is enabled, a * sign will be displayed after the current level value.

Operation Steps to Set the Measurement Level:

- 1) Select the AC level area on the screen. The menu area now displays the option to switch level type and add smaller functions.
- 2) You can modify and adjust your choices according to the menu prompts, or you can use the numeric keys to directly enter the desired value.

Note: If you need to switch the measurement level between current and voltage, you must use the menu area on the touch screen.

3.4.3.2 DC Level

Parameter Type: numeric input

As a measurement condition for DC resistance (RD).

DC Level Range:

Internal Resistance	DC Level Range	
30 Ω	0.1 V ~ 2 V	
100 Ω	All four parameters are RD	0.1 V ~ 20 V
	Other	0.1 V ~ 2 V

Level Voltage and Resolution:

Voltage Level (V_{rms})	Resolution
[0.1, 1]	1 mV
(1, 20]	10 mV

3.4.4 Speed

Parameter Type: select from list

The measurement speed is mainly determined by the following factors:

- Integration Time (A/D conversion)
- Average Number of Measurements (the number of measurements used to obtain the average value of the continuous measurement results)

- Measurement Delay (the time that passes between the trigger impulse until the measurement begins)
- Display Time of Measurement Results

Generally speaking, when measuring slowly, the measurement result will be more stable and accurate. You can choose between four measurement speeds.

Setting Options:

- FAST+
- FAST
- MED
- SLOW

See the description in section 6.1.9 for further details.

3.4.5 Range

The range is divided into AC range and DC range. The AC range is used to measure AC LCR parameters, and the DC range is used to measure DC resistance.

Parameter Type: select from list

The measurement range is selected according to the impedance value of the LCR component under test.

- **AC Measurement Range:** 0.1 Ω , 1 Ω , 10 Ω , 20 Ω , 50 Ω , 100 Ω , 200 Ω , 500 Ω , 1 k Ω , 2 k Ω , 5 k Ω , 10 k Ω , 20 k Ω , 50 k Ω , 100 k Ω .
- **DC Measurement Range:** 0.1 Ω , 1 Ω , 10 Ω , 20 Ω , 50 Ω , 100 Ω , 200 Ω , 500 Ω , 1 k Ω , 2 k Ω , 5 k Ω , 10 k Ω , 20 k Ω , 50 k Ω , 100 k Ω .

Operation Steps to Set the Measurement Range:

- 1) Use the cursor keys to move the cursor to the Range field. The screen will display the following soft keys:
 - **AUTO:** This soft key is used to set the range to AUTO (automatic) mode.
 - **HOLD:** This soft key is used to switch the range from AUTO mode to HOLD mode. When the range is set to HOLD mode, the range will be locked in the currently selected measurement range, which will be displayed in the range field of the screen.
 - **Increase (+):** This soft key is used to increase the range in HOLD mode.
 - **Decrease (-):** This soft key is used to decrease the range in HOLD mode.
- 2) Use the soft keys to set the measurement range.

3.4.6 DC Bias

Parameter Type: numeric input

This involves selecting bias source and type, setting the digital size range, as well as other related settings.

3.4.6.1 Bias Source

ST2840 series instruments come equipped with two types of internal bias source or external biases for selection. The corresponding options and input ranges are as follows:

Bias Source	Bias Type	Input Range
Internal 100 mA (Voltage, current, internal resistance are related to Ohm's law.)	Voltage	-40 V ~ 40 V
	Current	-100 mA ~ 100 mA
Internal 2 A	Current	0 A ~ 2 A
External ST1778	Current	0 A ~ 120 A (Determined by the external bias source)

3.4.6.2 Bias Type

When you are using the internal bias source of 100 mA, you can choose between the bias current mode or the bias voltage mode, and the maximum setting size is restricted by the relationship of the internal resistance.

Parameter Type: numeric input

Provides a built-in DC bias voltage ranging from -40 V to +40 V.

Press the [DC BIAS] key on the front panel to enable the set DC bias output. When the DC bias output is enabled, the [DC BIAS] button will be lit.

3.4.6.3 DC Isolation

Parameter Type: ON/OFF

The bias current isolation function can prevent the influence of DC current on the measurement input circuit. The function can be turned on or off using the ISO domain.

On the single measurement page (measurement display), the ISO switch control is determined by your individual settings. During list sweep and trace sweep measurements, when the current is above a certain level, it is automatically controlled by the set current.

Note: After the bias current isolation function is turned on, it will affect the test accuracy. Therefore, when measuring high-impedance components under low frequency and small bias current conditions, the bias current isolation function should be set to OFF.

3.4.6.4 Bias Polarity

Fixed or automatic mode.

3.4.7 Level Monitoring Function

The level monitoring function allows you to monitor the actual voltage across the DUT or the actual voltage and current values flowing through the DUT.

The voltage monitoring value is displayed in the Vm monitoring field on the <Meas Disp> page; the current monitoring value is displayed in the Im monitoring field on the <Meas Disp> page.

Parameter Type: ON/OFF

Note: The calibration function of the instrument has an influence on the level monitoring function. Therefore, when the correction data changes, the level monitoring value also changes. Turning on or off the open-circuit/short-circuit/load correction functions will also affect the level monitoring value.

3.4.8 Trigger Settings

This outlines the trigger mode, trigger delay, and step delay settings. Schematic diagram of trigger delay time and step delay time:

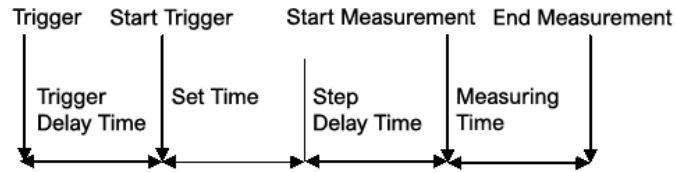

Note: The set time in the figure is the preparation time for the signal source control of the instrument measurement, range switching, etc.

3.4.8.1 Trigger Mode

Parameter Type: select from list

The choice of trigger mode determines the trigger condition of the instrument test. This series provides two different trigger modes to choose from.

- **Continuous Trigger Mode:** continuously repeating measurements
- **Single Trigger Mode:** Each time you press the [TRIGGER] key on the front panel, or each time the Handler Interface receives a positive pulse trigger signal/remote command, a trigger command is given, and a single measurement is taken.

Note: If, during measuring, another trigger signal is received, this signal will be ignored. Therefore, the trigger signal needs to be sent again after the measurement is completed.

When you need to trigger from the optional Handler Interface, set the trigger mode to single trigger mode.

3.4.8.2 Trigger Delay

Parameter Type: numeric input

Trigger delay refers to the delay time from when the instrument is triggered to the start of measurement. The trigger delay time setting range is 0 s ~ 60 s, and the minimum resolution is 1 ms.

This function can be particularly useful when the instrument is used in an automatic test system. When the instrument is triggered by the Handler Interface, the trigger delay time can ensure reliable contact between the DUT and the test terminal.

3.4.8.3 Step Delay

Parameter Type: numeric input

The step delay is the delay time from the output of the measurement signal to each measurement. The step delay time setting range is 0 s ~ 60 s, and the minimum resolution is 1 ms.

Note: There are *two* step delays in the RD measurement (because the voltage in the positive and negative directions needs to be added), so there are two measurement cycles. This means the *total* step delay time is twice the time you set here.

3.4.9 Average

Parameter Type: numeric input

The average function calculates the average of the results of 2 or more tests. The number of averages can be set from 1 ~ 255, and the minimum resolution is 1.

3.4.10 Automatic Level Control

The automatic level control function can adjust the actual measurement level (the voltage at both ends of the DUT or the current flowing through the DUT) to the set measurement level value as much as possible. Using this function can ensure that the test voltage or current at both ends of the DUT remains constant.

Parameter Type: ON/OFF

Note: When the constant level function is active, if the level setting exceeds the above range, the constant level function will be automatically set to OFF. The currently set level value is generally regarded as a non-constant level value.

3.4.11 Internal Resistance

When using the internal 100 mA bias current, the output of the signal source has an output resistance, and the output signals of other bias current modes are not output through this internal resistance.

Parameter Type: select from list

The internal resistance can be selected from 100 Ω or 30 Ω , and the default is 100 Ω . When measuring inductance, in order to compare data with other types of testers, it is necessary to ensure the same output resistance value.

Note: When using the internal 100 mA bias current output, 100 Ω internal resistance is recommended by default.

3.4.12 Deviation and Reference

3.4.12.1 Deviation Mode

Parameter Type: select from list

The deviation measurement function can make the deviation value (instead of real test value) be directly displayed on the screen. The deviation value is equivalent to the real test value subtracting the pre-set reference value. This function brings great convenience to observe variations of component parameters with temperature, frequency, bias. The instrument provides two deviation test modes as below:

Δ (Absolute Deviation Mode): The deviation currently displayed is the difference between the test value of the DUT and the preset reference value. The formula of calculating Δ ABS is as below:

$$\Delta = X - Y$$

Where:

- X is the test value of DUT.
- Y is the preset reference value.

$\Delta\%$ (Percentage Deviation Mode): The deviation currently displayed is the percentage of the difference between the test value of DUT and the preset reference value divided by the reference value. Its calculating formula is as below:

$$\Delta\% = (X - Y) / Y \times 100 [\%]$$

Where:

- X is the test value of DUT.
- Y is the preset reference value.

If the reference value is 0, the measurement result shows Inf.

3.4.12.2 Deviation Reference Value

Parameter Type: numeric input

This is the reference value used to calculate the deviation of the measurement result.

3.4.12.3 Reference Value Setting Method

Parameter Type: select from list

- Regular numerical input
- Automatic recording after measurement: Select the measurement function in the corresponding menu area of the reference, a test will be executed, and the measurement result will be recorded here as the parameter value.

3.5 <Limit Setup>

Press the menu key [SETUP], and then press the [Limit Setup] soft key to enter the <Limit Setup> page.

Limit Setup							Setup
Comp	OFF	Para	Cp	Xs	Z	θz°	Meas Setup
Count	OFF	Dev	OFF	OFF	OFF	OFF	Limit Setup
Mode	ToI	Ref	0.00000 F	0.00000 Ω	0.00000 Ω	0.00000 $^\circ$	List Setup
BIN1	OFF	Low	----	----	----	----	Trace Setup
		High	----	----	----	----	User Corr
BIN2	OFF	Low	----	----	----	----	Handler
		High	----	----	----	----	
BIN3	OFF	Low	----	----	----	----	
		High	----	----	----	----	
BIN4	OFF	Low	----	----	----	----	
		High	----	----	----	----	
BIN5	OFF	Low	----	----	----	----	
		High	----	----	----	----	
BIN6	OFF	Low	----	----	----	----	
		High	----	----	----	----	
BIN7	OFF	Low	----	----	----	----	
		High	----	----	----	----	
BIN8	OFF	Low	----	----	----	----	
		High	----	----	----	----	
BIN9	OFF	Low	----	----	----	----	
		High	----	----	----	----	
BIN10	OFF	Low	----	----	----	----	
		High	----	----	----	----	

Figure 3-13 Limit Setup Page

The comparator function of the instrument can be set on this page. 10 BIN limits can be set, and the measured results can be sorted into up to 11 BINs (BIN1 to BIN10 and BIN OUT).

- Comparator Function
- Comparator Count Function
- Comparator Function Limit Mode
- Parameters to Compare
- Deviations
- References (reference value in deviation mode, namely nominal value)
- Sorting BINs ON/OFF
- Lower Limit Value of Each BIN (Low)
- Upper Limit Value of Each BIN (High)

3.5.1 Comparator Function

Parameter Type: ON/OFF

3.5.2 Comparator Count Function

Parameter Type: ON/OFF

3.5.3 Comparator Function Limit Mode

Parameter Type: select from list

The comparator function provides the two parameter limit setting modes, as shown in the figure below.

- **Sequential Mode:** In sequential mode, the test value range is used as the comparison limit value. The comparison limit value must be set in ascending order.
- **Tolerance Mode:** In tolerance mode, set the deviation value from the nominal value (the nominal value is set in the nominal field) as the comparison limit value. There are two ways of deviation: one is the percentage deviation, and the other is the absolute deviation.

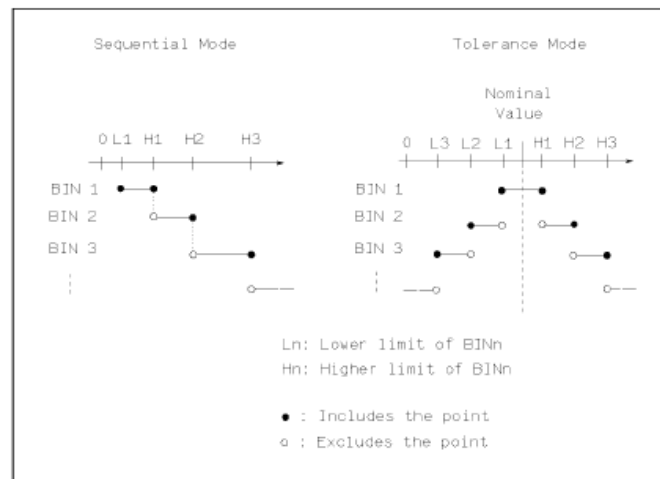

Figure 3-14 Sequential Mode and Tolerance Mode

Note: When setting the limit value in tolerance mode, the error range must be set from small to large. If the error range set by BIN1 is the largest, then all the measured parts will be sorted into BIN1 file.

In tolerance mode, the lower limit does not have to be less than the nominal value, and the upper limit does not have to be greater than the nominal value. The limits of each BIN can be discontinuous or overlapping.

3.5.4 Parameters to Compare

Comparing parameters refers to the four measurement parameters; the sorting parameters can be modified on the measurement display page or the measurement setting page.

3.5.5 Deviations and References

Refer to the setting of the deviation and reference on the measurement settings page; the meaning of the parameter here is exactly the same.

3.5.6 Sorting BIN ON/OFF

Parameter Type: ON/OFF

When the corresponding sorting BIN is OFF, the sorting process will skip this sorting limit comparison.

3.5.7 High/Low Limits

These act as the main basis for parameter comparison. If the upper and lower limits of the corresponding BIN are not set, it indicates that the parameter in the corresponding BIN does not participate in the comparison, that is, the measurement result does not affect the comparison result.

Parameter Type: numeric input

Note: When only the upper or only the lower limit is set, it is regarded as a unilateral comparison.

3.6 <List Setup>

Press [SETUP] and then [List Setup] to enter into the <List Setup> page as shown below.

List Setup								Setup
Total Point	8	Trigger Mode	Continue	List Mode	Seq			
Pt	Freq	Level	Bias	Para1/4			Delay	
				Func	Low	High		
1	1.00000kHz	1.00000 V	0.00000 A	Cp	-----	-----	0 s	Meas Setup
2	1.00000kHz	1.00000 V	0.00000 A	Cp	-----	-----	0 s	Limit Setup
3	1.00000kHz	1.00000 V	0.00000 A	Cp	-----	-----	0 s	List Setup
4	1.00000kHz	1.00000 V	0.00000 A	Cp	-----	-----	0 s	Trace Setup
5	1.00000kHz	1.00000 V	0.00000 A	Cp	-----	-----	0 s	User Corr
6	1.00000kHz	1.00000 V	0.00000 A	Cp	-----	-----	0 s	Handler
7	1.00000kHz	1.00000 V	0.00000 A	Cp	-----	-----	0 s	
8	1.00000kHz	1.00000 V	0.00000 A	Cp	-----	-----	0 s	

Figure 3-15 List Setup

The list sweep function can perform auto sweep test for the measurement frequency, level or bias voltage of 201 points.

On the <List Setup> page, the following list sweep parameters can be set:

- Number of Scan Points
- Trigger Mode
- List Mode
- Difference Mode
- Sweep Condition (frequency [Hz], level [V], level [I], bias [V], bias [I])
- Parameter Function
- High/Low Limit (HIGH, LOW)
- Comparison
- Single Point Delay (DELAY[s])

3.6.1 Number of Scan Points

Set the number of points to be scanned for list sweep; the value range is 1 ~ 201.

3.6.2 Trigger Mode

This is the same as the trigger mode on the measurement settings page. After the list sweep is triggered normally, the user can interrupt the list sweep process by pressing the [RESET] button:

- Press [RESET] once to pause, and continue scanning at the current point at the next trigger;
- Press [RESET] twice to reset, and restart scanning from the first point at the next trigger.

3.6.3 List Mode

Set the list sweep mode, choosing between sequential mode or single-step mode.

Parameter Type: select from list

- **Sequential Mode:** Upon receiving a trigger signal, the instrument will sweep sequentially from the first to the last point.
- **Single-Step Mode:** Upon receiving a trigger signal, only one point can be tested at a time.

Note: The effect of the list mode is mainly reflected in the single-step mode. When in sequential mode, the test process of the two modes will be visually different.

3.6.4 Difference Mode

In the list scan of parameter 1, the scan point n (range 1 ~ 201) is compared with the parameter 1 reading of scan point 1 or scan point 2 by difference.

When the comparison function (section 3.6.8) is enabled and the difference mode is **disabled**, the list display page is as shown in Figure 3-4 in section 3.2, and the PASS/FAIL result output is based on the upper and lower limit comparison results of the measured data of parameters 1 to 4.

When the comparison function (section 3.6.8) is enabled and the difference mode is **enabled**, the list display page is as described at the end of section 3.2 and the difference calculation result is displayed at the same time.

The PASS/FAIL result is then output based on the comparison result of the difference calculation result.

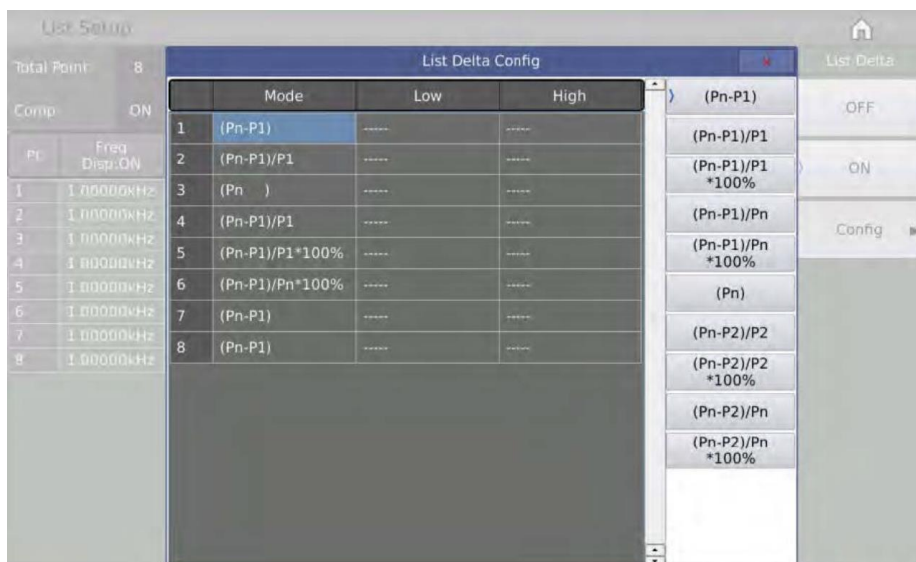

Figure 3-16 Difference Mode Configuration

3.6.5 Sweep Condition

Frequency, level, and bias can be set independently, and can also be quickly set to make one of the conditions remaining relatively regular. If you are only concerned about the impact of one condition change on the DUT, you can quickly set other measurement conditions to the same result, such as a linear change in frequency, and a fixed level and bias.

Regarding the frequency, level and bias in the sweep condition, you can choose whether to display it on the test page, touch the title area corresponding to the parameter, and then select ON or OFF on the corresponding menu.

3.6.6 Parameter Functions

Four parameter functions, all of which can be set independently, and can also be quickly set to make one of the conditions relatively consistent.

Since the upper and lower limits involved in setting the limits using the 4-parameter setting method would result in excessively long panning effects, a parameter display menu is used to achieve the function of setting the upper and lower limits of one of the parameters. The parameter display menu here is only used to select the parameter index that is currently being set, and has no direct relationship to whether the parameter is being measured.

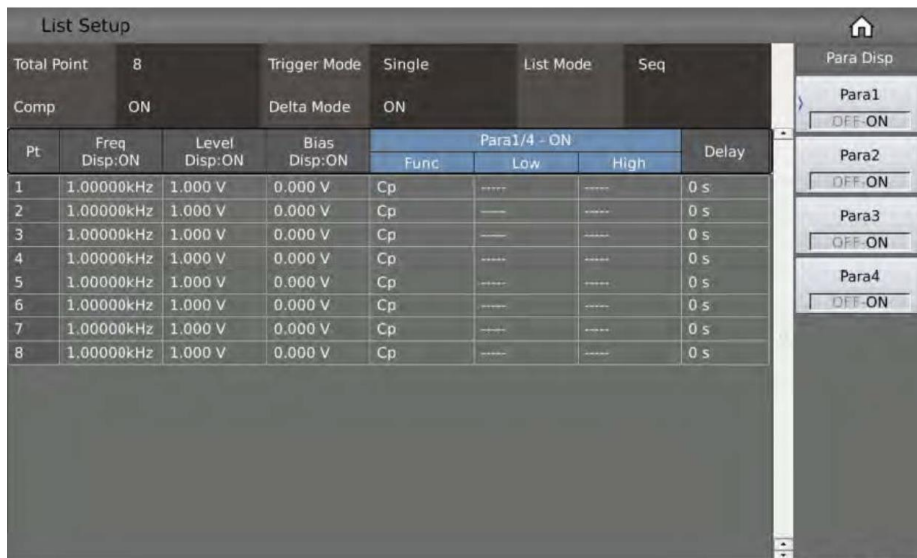

Figure 3-17 List Parameter Display Menu

3.6.7 High/Low Limits

The upper and lower limits of the parameters can be set independently, and can also be set quickly to make the settings have a specific ratio.

3.6.8 Comparison

The upper and lower limits of the parameters are used as the main basis for comparing the parameters. When differential mode is enabled, the P/F result is displayed by comparing the upper and lower limits of the difference of parameter 1. Parameter 2 is used only to display the measurement result and does not participate in the comparison.

Parameter Type: ON/OFF

3.6.9 Delay

The delay parameter indicates the delay time from the completion of each sweep step measurement to the next sweep measurement. It is mainly used to connect an external bias source (such as ST1778) to adapt to the delay time setting required by the external bias current source.

Note: The delay here can be accumulated with the delay in the measurement setting interface.

3.7 <Trace Setup>

Press [SETUP] and then [Trace Setup] to enter into the <Trace Setup> page.

Trace Setup						Setup
Frequency	100.000kHz	Speed	Fast+	DC Bias	0.000 V	Meas Setup
AC Level	1.000 V	AC Range	Auto	Split	4	Limit Setup
DC Level	1.000 V	DC Range	Auto	Sweep Point	101	List Setup
Trigger Mode	Continue	Sweep Type	Freq[Hz]	Trace Mode	Seq	Trace Setup
Trigger Delay	0 s	Start	20.0000	X Format	Linear	User Corr
Step Delay	0 s	Stop	1.00000k	Max-Min	ON	Handler
Parameter1	Rs	Min1	-7.33663M	Max1	646.932k	
Parameter2	Xs	Min2	-3.20232M	Max2	47.1887M	
Parameter3	Z	Min3	-3.25359M	Max3	47.7547M	
Parameter4	θz°	Min4	89.2958	Max4	110.409	

Figure 3-18 Trace Setup

This display function page is used to complete the setting of trace sweep measurement parameters, including...

- Split Screen
- Number of Scan Points
- Sweep Type
- Start and Stop Conditions
- Trace Mode
- X Format
- Max/Min Values
- Parameters
- Y Display Range, etc.

3.7.1 Common Measurement Settings

Frequency, level, speed, range, offset, trigger, delay, etc. are all common measurement conditions, and their meaning and setting method are exactly the same as the description on the measurement settings page.

3.7.2 Sweep Parameters

The 4 sweep parameters are used to specify the result parameters of the trace sweep, that is, to draw the measurement results under certain conditions into a curve.

The sweep parameters and the conventional component 4 test parameters are independent of each other and not directly related. Optional parameters can be selected, except for RD. The sweep parameters correspond to 4 curves; each curve has independent display switch, display scale and independent ordinate scale, but share the same abscissa scale.

3.7.3 Spilt Screen

For the curve display effect, 3 kinds of split screen display are available:

Parameter Type: select from list

- **1-Split / None:** All four curves are displayed in the same drawing window.
- **2-Split:** The four curves are grouped in pairs and displayed in the corresponding drawing window.
- **4-Split:** The four curves are displayed independently in their respective drawing windows.

3.7.4 Number of Scan Points

This is the number of points to be scanned. There are five groups of 51, 101, 201, 401, 801 to choose from.

3.7.5 Sweep Type

The sweep type is mainly used to set the conditions of the trace sweep, that is, to plot the measurement results according to the selected condition parameters, so it involves the type of condition parameters, the start size and the stop size of the condition change.

Set the main conditions corresponding to the sweep curve, namely frequency [Hz], level [V], level [A], bias [V], bias [A]:

Sweep Type	Description	Linear	Logarithmic
Freq [Hz]	The condition changes within the specified interval (between start and stop), and record the corresponding parameter results after changing in a linear or logarithmic relationship	√	√
Level [V]		√	×
Level [A]		√	×
Bias [V]		√	×
Bias [A]		√	×

3.7.5.1 Start and Stop Conditions

After selecting the sweep type, set the start size and stop size of the corresponding conditions; that is, the start and stop points of the trace sweep.

3.7.6 Trace Mode

Set the trace sweep mode to either sequential mode or single-step mode.

Parameter Type: select from list

- **Sequential Mode:** Upon receiving a trigger signal, the instrument will sweep sequentially from the first to the last point.
- **Single-Step Mode:** Upon receiving a trigger signal, only one point can be tested at a time.

Note: The effect of the trace mode is mainly reflected in single-step mode. If the instrument is in sequential mode, the test process of the two modes will be visually different.

3.7.7 X Format

This area is used to change the coordinate mode of sweep, mainly for the abscissa.

Parameter Type: select from list

- **Linear:** The sweep condition parameters are linearly distributed within the start and stop ranges.
- **Logarithmic:** The sweep condition parameters are distributed in a logarithmic manner with the base 10 within the start and stop ranges.

Note: For the scan frequency, the logarithmic mode is the only valid option.

3.7.8 Max/Min

Parameter Type: ON/OFF

- **ON:** Display the maximum and minimum values of the parameter curve results
- **OFF:** Do not display the maximum and minimum values of the parameter curve results

3.7.9 Comparison

Provides a comparison function for curve data that includes a range comparison of the entire parameter, a comparison of the minimum and maximum values of the specified curve, a comparison of the abscissa corresponding to the minimum and maximum values, and a comparison of the relevant piezoelectric test parameters.

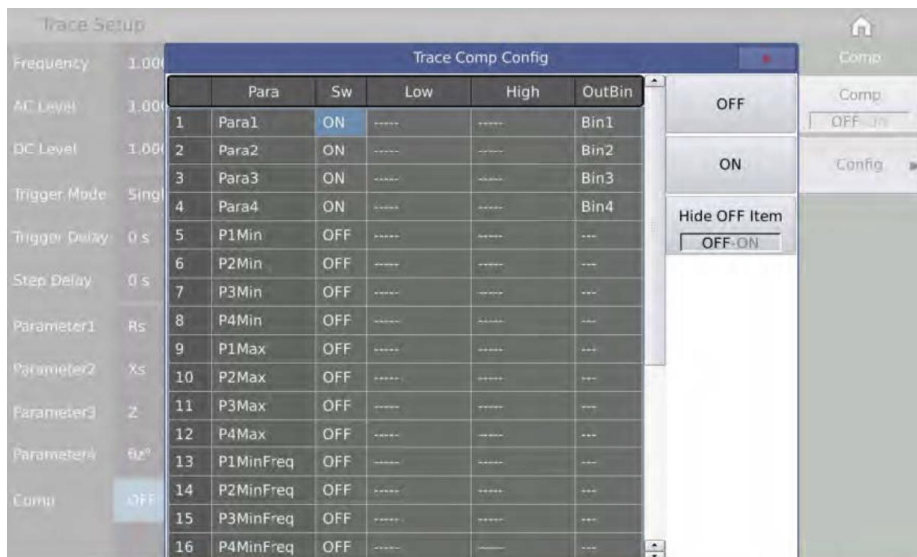

Figure 3-19 Trace Comparison Configuration

3.8 User Correction

Ten user Pt are provided on the <User Corr> page. In the Freq domain, you can set whether the calibration data of the corresponding point is turned on. After turning on, manually enter the frequency corresponding to the calibration, and then use the soft key [Open] to execute open-circuit correction, short-circuit correction, and load correction for the set frequency.

Press the menu key [SETUP], and press the soft key [User Corr] to access the <User Corr> page.

User Corr										Home
Open	ON	Load Type		Ls~Rs						Setup
Short	ON	Cable		0m						Meas Setup
Load	OFF									Limit Setup
Pt	Freq (Hz)	Ref		Open		Short		Load		List Setup
		Ls(H)	Rs(Ω)	G(S)	Cp(F)	R(Ω)	Ls(H)	Ls(H)	Rs(Ω)	
1	1.0000k	0.00000μ	20.000m	0.04853μ	22.9121p	2.09409M	-991.362	0.00000μ	0.000m	Trace Setup
2	10.000k	0.00000μ	0.000m	0.00000μ	0.00000p	20.228m	0.04900μ	0.00000μ	0.000m	User Corr
3	100.00k	0.00000μ	0.000m	0.00000μ	0.00000p	21.588m	0.03198μ	0.00000μ	0.000m	Handler
4	100.000	0.00000μ	0.000m	0.00000μ	0.00000p	42.4278M	--.---k	0.00000μ	0.000m	
5	OFF	-----	-----	-----	-----	-----	-----	-----	-----	
6	OFF	-----	-----	-----	-----	-----	-----	-----	-----	
7	OFF	-----	-----	-----	-----	-----	-----	-----	-----	
8	OFF	-----	-----	-----	-----	-----	-----	-----	-----	
9	OFF	-----	-----	-----	-----	-----	-----	-----	-----	
10	OFF	-----	-----	-----	-----	-----	-----	-----	-----	

Figure 3-20 User Correction

The open-circuit, short-circuit and load correction functions on the <User Corr> page can be used to eliminate distributed capacitance, parasitic impedance and other measurement errors.

Parameter Type: select from list

- **Full Frequency Correction:** Use insertion method to execute open-circuit and short-circuit correction of all frequency points.
- **Point Frequency Correction:** Execute open-circuit, short-circuit and load correction of the current set frequency point.

The following measurement control parameter setting domains can be set on the <User Corr> page:

- Open-Circuit Correction (Open)
- Short-Circuit Correction (Short)
- Load Correction (Load)
- Cable Length Selection (Cable)
- Load Type
- Point Frequency Correction Switch
- Reference Value; etc.

3.8.1 Open-Circuit Correction

The open-circuit correction function can eliminate the error caused by the stray admittance (G, B) connected in parallel with the component under test, as shown in the figure below:

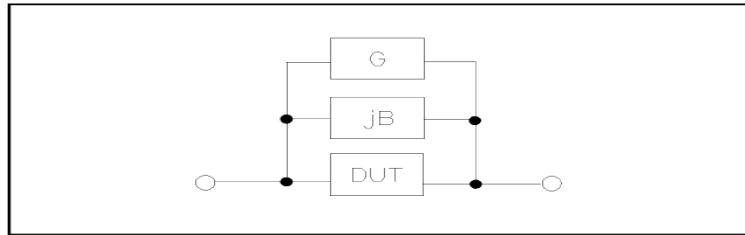

Figure 3-21 Stray Admittance

The following two open-circuit correction data are used:

Regardless of the frequency you currently set, perform an open-circuit correction test on all the following fixed frequency points. In addition, based on the open-circuit correction data at the following frequency points, the instrument can calculate all open-circuit correction data of different measurement ranges which corresponds to all test frequencies by using the interpolation calculation method. Move the cursor to the Open field, and use the soft key [Meas Open] to execute the full frequency open-circuit correction. The fixed frequency points are as follows (some models will be limited due to different frequency ranges).

20 Hz	25 Hz	30 Hz	40 Hz	50 Hz
60 Hz	80 Hz	100 Hz	120 Hz	150 Hz
200 Hz	250 Hz	300 Hz	400 Hz	500 Hz
600 Hz	800 Hz	1 kHz	1.2 kHz	1.5 kHz
2 kHz	2.5 kHz	3 kHz	4 kHz	5 kHz
6 kHz	8 kHz	10 kHz	12 kHz	15 kHz
20 kHz	25 kHz	30 kHz	40 kHz	50 kHz
60 kHz	80 kHz	100 kHz	120 kHz	150 kHz
200 kHz	250 kHz	300 kHz	400 kHz	500 kHz
600 kHz	800 kHz	1 MHz	1.1 MHz	1.2 MHz
1.3 MHz	1.4 MHz	1.5 MHz	1.6 MHz	1.7 MHz
1.8 MHz	1.9 MHz	2 MHz		

Operation Steps to Use the Open-Circuit Correction Function:

Open-circuit correction includes full frequency open-circuit correction using interpolation calculation method, and single frequency open-circuit correction for the set frequency point. Carry out the following steps to perform open-circuit correction for full frequency using the interpolation calculation method. For details about single-frequency open-circuit correction, please refer to the "Load Correction" operating instructions.

Move the cursor to the Open setting field, and the following soft keys are displayed in the soft key area of the screen:

- **OFF:** Turn off the open-circuit correction function. The calculation of open-circuit correction will no longer be carried out in the subsequent measurement process.
- **ON:** Turn on the open-circuit correction function, and the correction calculation will be performed in the subsequent test process. If the frequency settings are all OFF, the open-circuit correction calculation uses the correction data of the current frequency calculated by the interpolation method. If the frequency is set to ON, and the current measurement frequency is equal to the corresponding frequency, the correction data of the corresponding frequency will be used for the calculation of the open-circuit correction.

- **Meas Open:** The open admittance (capacitance and inductance) at the above fixed frequency point will be measured. The open-circuit full-frequency correction takes about 75 s.
- **DCR Open:** The open-circuit resistance measurement under the DC resistance function will be performed.

Note: Connect the test fixture to the test terminal of the instrument. The fixture is open and not connected to any component under test.

3.8.2 Short-Circuit Correction

The short-circuit correction function of ST2840 series instruments can eliminate errors caused by spurious inductance (R, X) in serial with DUT, as shown in the following figure:

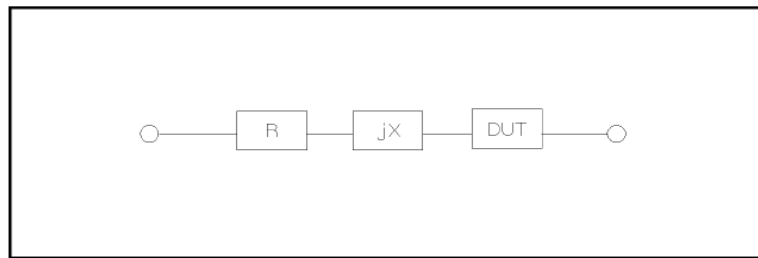

Figure 3-22 Spurious Inductance

The following two short-circuit correction data is used:

Regardless of the frequency you currently set, perform a short-circuit correction test on all the following fixed frequency points. In addition, based on the short-circuit correction data at the following frequency points, the instrument can calculate all short-circuit correction data of different measurement ranges which corresponds to all test frequencies by using the interpolation calculation method. Move the cursor to the Short field, and use the soft key [Meas Short] to execute the full frequency short-circuit correction. The fixed frequency point is the same as the open-circuit correction.

Operation Steps to Use the Short-Circuit Correction Function:

The short-circuit correction includes the full-frequency short-circuit correction using the insertion calculation method and the single-frequency short-circuit correction for the set frequency point. Perform the following steps to perform short-circuit correction at full frequency using the insertion calculation method. For details on single-frequency short-circuit correction, please refer to the "Load Correction" operating instructions.

Move the cursor to the short-circuit setting field, and the following soft keys are displayed in the soft key area of the screen:

- **OFF:** Turn off the short-circuit correction function. The calculation of short-circuit correction will no longer be carried out in the subsequent measurement process.
- **ON:** Turn on the short-circuit correction function, and the correction calculation will be performed in the subsequent test process. If the frequency settings are all OFF, the short-circuit correction calculation uses the correction data of the current frequency calculated by the interpolation method. If the frequency is set to ON, and the current measurement frequency is equal to the corresponding frequency, the correction data of the corresponding frequency will be used for the calculation of the short-circuit correction.
- **Meas Short:** Connect the test fixture to the test terminal of the instrument. Short-circuit the test fixture with a short-circuit strip. Press the soft key [Meas Short], and the parasitic impedance (resistance and reactance) at the above fixed frequency point will be measured. The short-circuit full-frequency correction takes about 75 s.
- **DCR Short:** The short-circuit resistance measurement under the DC resistance function will be performed.

3.8.3 Load Correction

The load correction function uses the transfer coefficient between the actual test value at the set frequency point and the standard reference value to eliminate other test errors. It can be seen that open circuit, short circuit and load correction can be performed at the set frequency point. Before setting the standard reference value, the reference value must be set in the reference value corresponding field. When the cursor moves to Freq or Ref, the screen displays the soft key [Load]. Press the [Load] key to perform a load correction test on the standard.

Parameter Type: ON/OFF

- **OFF:** Deactivate the load calibration test data under the current set frequency.
- **ON:** Activate the load calibration test data under the current set frequency.

3.8.3.1 Load Type

When performing load correction, the reference value of the standard device must be input in advance.

The test parameters of the reference value should be consistent with the set load correction measurement function. The load correction function uses the transfer coefficient between the actual test value at the set frequency point and the standard reference value to eliminate other test errors. The load correction measurement function is only used to calculate the transfer coefficient.

This series categorizes the load types into 3 categories:

- $L_s \sim R_s$
- $L_s \sim Q$
- $C_p \sim D$

3.8.4 Cable

The cable length currently available is 0 m and 1 m. The factory default is 0 m.

3.8.5 Point Frequency Operation

Follow the steps below to perform an open/short/load correction test on the set frequency point. Move the cursor to the frequency setting area. The screen will display the following soft keys:

- **OFF:** Deactivate the open-circuit/short-circuit/load correction data at the currently set frequency.
- **ON:** Activate open-circuit/short-circuit/load correction data at the currently set frequency; the frequency setting field then displays the originally set open-circuit/short-circuit/load correction frequency.
- **Open:** Perform an open-circuit correction at the current frequency.
- **Short:** Perform a short-circuit correction at the current frequency.
- **Load:** Perform a load correction at the current frequency.

Operation Steps to Use the Load Correction:

- 1) Move the cursor to the FREQ setting area, and set the frequency to be calibrated.
- 2) Open the test fixture, and press the soft key [Open] to perform open-circuit correction for the current set frequency.
- 3) Short-circuit the test fixture and press the soft key [Short] to perform short-circuit correction for the current set frequency.
- 4) Prepare a measurement standard device, move the cursor to the Load Type setting field, and set the type of function parameters that the standard device needs to measure.

- 5) Move the cursor to the corresponding frequency setting domain, connect the standard device to the test fixture, press the soft key [Load], and the instrument will perform a load calibration. The actual measurement result of the standard device is displayed on the load.

3.9 Handler Settings

























LCR Handler								Function
Handler	User define							
Pin	Signal	Direction	Function	Pin	Signal	Direction	Function	
1	BIN1	Output		14,15	ExtDCV2	Input	3.3V ~ 24V	OFF
2	BIN2	Output		16,17,18	+5V	Output	I _{max} < 0.3A	OFF
3	BIN3	Output		19	Pass	Output		
4	BIN4	Output		20	Fail	Output		
5	BIN5	Output		25	Lock	Input		
6	BIN6	Output		27,28	ExtDCV1	Input	3.3V ~ 24V	
7	BIN7	Output		29	Alarm	Output		
8	BIN8	Output		30	Index	Output		
9	BIN9	Output		31	Eom	Output		
10	BIN10	Output		34,35,36	Com1	Input	GND1	
12,13	ExtTrig	Input		32,33	Com2	Input	GND2	
11,21,22 23,24,26	Reserve							

Figure 3-23 Handler Settings

The input and output I/O interfaces are active low by default, and the trigger mode can be changed as needed. For details on the handler interface, refer to Chapter 8 Handler Interface Description.

4 System and File

4.1 <System Setup>

Press the menu key [SYSTEM] to enter the <System Setup> page.

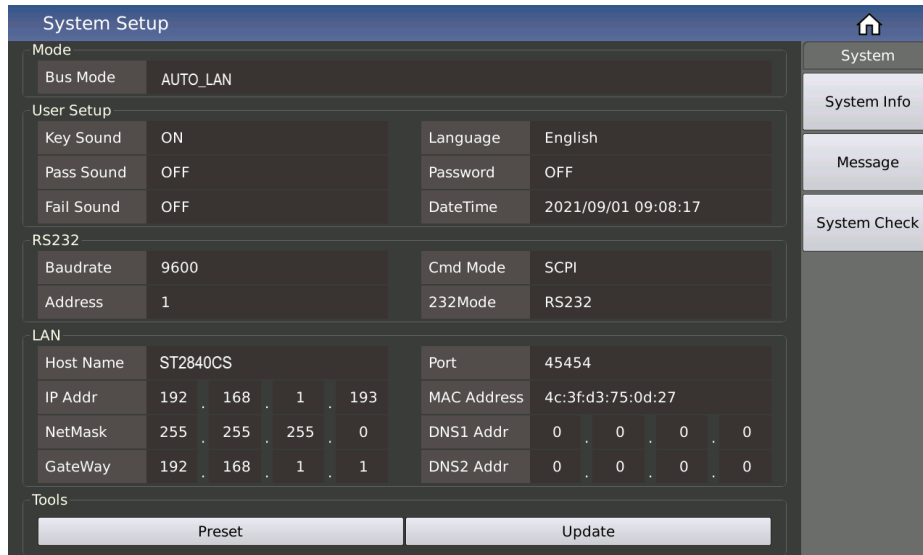

Figure 4-1 System Setup

This function page displays most of the system setup menus, including the meter function, beeper on, pass beep, fail beep, system language, password setting, bus mode, GPIB address, talk only, baud rate, time, etc.

4.1.1 Mode Setup

Bus Mode: The bus mode is used to select the communication mode of the instrument.

Setting Option	Description
AUTO	Automatically select the RS232/LAN/USB communication mode according to the external signal input
RS232	RS232
	External 485
	External GPIB
LAN	–
USB Device	USBCDC
	USBTMC

Note: The Sourcetronic GPIB option must be installed to support the GPIB mode.

When using the RS485 or GPIB interface, the bus address under the RS232 setting will be used as the local address.

4.1.2 User Setup

4.1.2.1 Key Sound

Parameter Type: ON/OFF

4.1.2.2 Pass Sound

Parameter Type: select from list

This parameter is used to control and display the sound mode when the measurement comparison result of the instrument is qualified.

Setting Options:

- OFF
- Two Short
- Low Long
- High Short
- High Long

4.1.2.3 Fail Sound

Parameter Type: select from list

This parameter is used to control and display the alarm sound mode when the measurement comparison result of the instrument is defective.

Setting Options:

- OFF
- Two Short
- Low Long
- High Short
- High Long

4.1.2.4 System Language

Parameter Type: select from list

This parameter is used to control and display the operating language currently set on the instrument.

Setting Options: English/Chinese

4.1.2.5 Password

This parameter shows the current password protection mode.

Parameter Type: select from list type + input type

- **OFF:** Turn off password protection
- **Lock System:** Activate password protection, including file protection
- **Lock File:** File protection for users

- **Lock Setup:** used to restrict modifications on the settings file
- **Modify:** This soft key is used to change the password. After pressing this button, enter the new password according to the prompt on the screen. After inputting from the keyboard, the screen prompts to confirm the new password, repeat the new password, and the password modification is completed.

Note: The factory default password is **2840**.

4.1.2.6 Date/Time

Here you can modify the system time and date.

4.1.3 RS232 Settings

The general setting parameters of the serial port are: 8 data bits, 1 stop bit, no parity bit.

4.1.3.1 Baud Rate

Parameter Type: select from list

This parameter is used to select the baud rate of the built-in RS232 interface of the instrument.

Setting Options:

- 4800
- 9600
- 19200
- 38400
- 57600
- 115200

4.1.3.2 Bus Address

Parameter Type: numeric input

This parameter is used to control and display the RS485, GPIB interface and Modbus address.

Value Range: 1 ~ 32

4.1.3.3 Command Mode

This parameter is used to set the command mode with SCPI command and modbus command protocol.

Parameter Type: select from list

- **SCPI:** Adopt general ASCII string command protocol
- **Modbus:** Adopt modbus command protocol

For a more detailed introduction, please refer to Chapter 7 Command Reference.

4.1.4 LAN

Configure the corresponding address parameters according to the specific attributes of the connected LAN, and plug in the network cable on the rear panel to use the network port for communication.

If you need to modify the relevant address parameters, you can directly double-click the corresponding address display window to pop up the numeric keyboard, enter the correct network configuration on the numeric keyboard, and click OK to exit the keyboard to complete the modification;

If the connected networking equipment (router or switch) supports the automatic IP allocation function, you can directly click the automatic configuration button in the display window to try the automatic configuration. The configuration takes a few seconds. Do not operate the machine during the configuration process. If the equipment does not support it, you need to manually assign the setting address.

If the automatic configuration fails, you may get the loopback IP address of the machine, that is, 127.0.0.1; at this time, you can click the default setting button in the display window to restore the default configuration, and then start again on the basis of the default configuration. Just make fine adjustments, and you can consult the company's network technical engineer to obtain the address parameters of the network configuration.

Default Port Number: 45454

The host name generally corresponds to the instrument model.

4.1.5 Tools

4.1.5.1 Preset

For the convenience of customers, the instrument can be initialized to a known unified initial state.

Standardize initial software operation design in order to solve the problem of inconsistent setting status when the instrument leaves the factory.

Nr.	Option	Description	Command
1	CLEAR SETTING	Restore the following parameters to the factory default settings: a. Parameters set through front panel operation b. Parameters set by SCPI commands	*RST
2	CLEAR SET & CORR	Restore the following parameters to the factory default settings: a. Parameters set through front panel operation b. Parameters set by SCPI commands c. Power-off protection parameters d. Clear user correction data	:SYST:PRES
3	FACTORY DEFAULT	Restore the following parameters to the factory default settings: a. Parameters set through front panel operation b. Parameters set by SCPI commands c. Power-down protection data d. Clear user reset data e. Clear files saved by users	:SYS:DEFT

Note: Parameters that cannot be initialized:

- The initialization operation is not allowed to clear the system calibration data.
- The real-time clock date and time are not allowed to be cleared or initialized.

4.1.5.2 Software Update

This function is used for software version updates and maintenance. ST2840 series instruments are designed with multiple CPUs. For your convenience, a one-key option to update firmware is provided. After the one-key update, you need to wait only about 15 seconds (refer to the prompts on the screen). After the update is completed, the instrument will automatically restart. After restarting, you can return to this menu to check that the software version you are now using is the latest version.

The instrument provides several options for software updates, including performing the update directly on the specified file in the file system management list, or using the default upgrade path (that is, performing the upgrade by running the "usb/update2840.sec" file).

To do so, simply place the "update2840.sec" file in the root directory of the USB flash drive; the device will now perform the update. This can also be used in conjunction with our own PC tool to update the specified file on the PC.

The menu is shown in Figure 4-2:

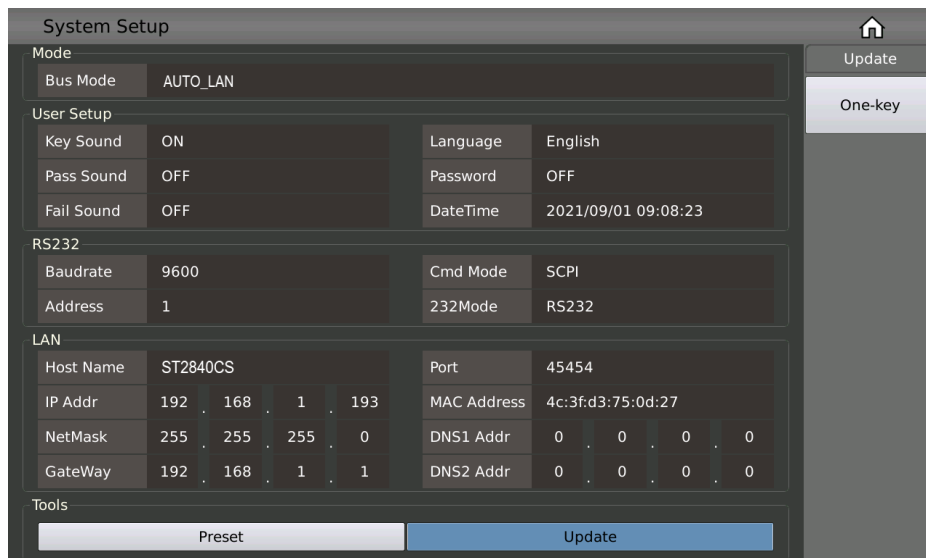

Figure 4-2 Update Menu

The dynamic prompt window of the one-click upgrade is shown in Figure 4-3:

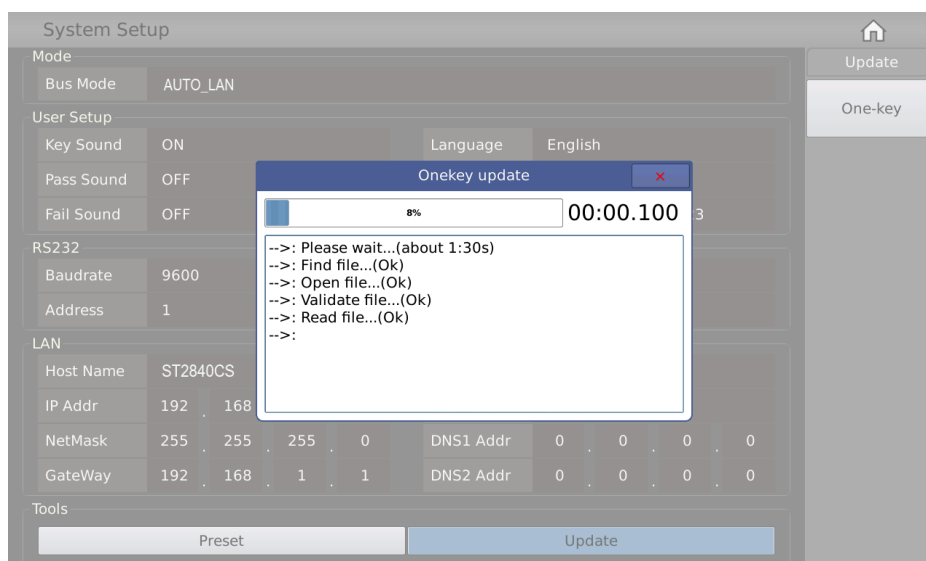

Figure 4-3 Update Pending Prompt

4.2 <File>

As your instrument is equipped with an embedded file system, it can be very convenient to store the custom-set parameters as a file, either in the system's internal drive or on an external USB drive. This way you won't have to re-configure the parameters next time if you want to use the same settings again; you can simply load the corresponding file, saving you time and improving efficiency.

Press the soft key [FILE] to enter the <File> function page.

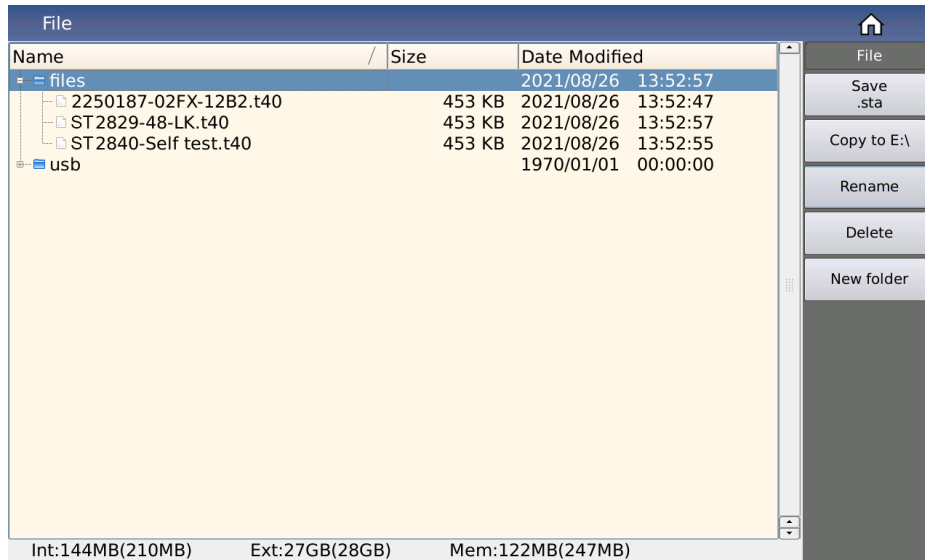

Figure 4-4 File Function Page

4.2.1 USB Drive Performance Management

As mentioned above, this series comes equipped with a USB host interface. An external USB flash drive can be used as a storage medium, thus breaking the limitation of the internal storage size of the instrument. You can also copy these files to an IBM PC with a USB interface or a desktop computer or Notebook computers compatible with it, so as to achieve unlimited expansion.

Supports USB storage devices (USB flash drives) that fulfil the following criteria:

- Compliant with USB 2.0 standard
- File format: FAT16 or FAT32 (formatted with Microsoft Windows operating system)

4.2.2 Introduction to the Save/Load Function

Using the save/load function, you can save configuration information either to the device's own internal drive or to an external USB flash drive, and in turn load files from there.

Setting Options:

- **files:** internal file
- **usb:** external file

The following table explains the available storage methods and their uses:

Storage Method		Loadable	Usage
Type	File Format		
LCR Settings	*.sta	Yes	Save the LCR measurement configuration status.
Screenshot	*.png	No	Save a screenshot of the display.
Measurement Data	*.csv	No	Save measurement data

Note: Measurement results and screenshots can only be saved to the external USB flash drive.

4.2.3 Basic Menu Operations of File Management

The various operations on the file are as follows:

The up and down keys and the knob of the arrow keys are used to move the file cursor up and down, and the left and right keys of the arrow keys are used to operate the expanded state of the current path;

Click to select the file name to be operated, and the operation can be performed as follows according to the toolbar on the right side of the screen:

- **Save .sta:** This refers to the LCR mode. The default menu is the corresponding file save menu. When the cursor is on the files path, the measurement will be carried out after inputting the file name. The settings file is saved in the root directory.
- **Copy to E:\:** When the cursor is on an internally stored file or folder, this will copy it to the USB root directory.

Note: If you are copying a single file, it will overwrite any file of the same name in the USB path; if you are copying a folder, please make sure that there is no folder with the same name in the USB root directory, otherwise it will cause the error message "Copy Failed".
- **Copy to I:\:** When the cursor is on a file or folder stored on the USB device, this will copy it to the internal root directory.
- **Delete:** Delete the file or folder at the cursor's position.
- **Load:** Load the settings file specified by the file index to re-configure the parameter settings of the instrument.
- **Rename:** Rename the file or folder at the cursor's position.

Note: The root directory provided is not modifiable.
- **New Folder:** Create a new folder directory at the current cursor location; you can save a new test file in the newly created folder directory.

4.2.4 Operation Steps for File Management (Save/Load)

Move the cursor using the up and down arrow keys and the knob; expand and zoom in and out using the left and right arrow keys of the arrow keys.

4.2.4.1 Save File

Move the cursor to the folder or any file in the folder where you want to save the settings file, and the corresponding menu area will display the file menu:

- Load (if it is a loadable file type)
- Save
- Copy to E:\
- Rename
- Delete
- New folder

Press the [Save] soft key, the screen will display a numeric keyboard to input the file name. The file name suffix is automatically generated, so only the first part of the file name needs to be input manually. After the input is confirmed, your file should show up in the directory.

4.2.4.2 Load File

When you move the cursor to a loadable file in the file list or directly enter the file number of a loadable file, this option will be displayed.

Press the [Load] soft key, and the following confirmation dialog box will be displayed on the screen:

- **Load:** The currently selected file is loaded. After loading, the instrument will automatically return to the corresponding measurement display page.
- **Cancel:** Cancel the current loading operation and return to the previous screen.

4.2.4.3 Copy File

When you move the cursor to the folder or file to be copied, the menu area will display:

- **Copy to E:\:** Copy the file to the root directory of the external storage USB disk.
- **Copy to I:\:** Copy the file to the internal root directory of the instrument.

Note: Please make sure that your USB flash drive meets the standards described in this section and is not set to read-only mode (write-protected).

5 Execute LCR Measurement and Some Examples

5.1 Corrections

You can select one of two correction modes (applied to the entire list via sweep mode or applied to one specific frequency point) to execute an open-circuit or short-circuit correction; this will help prevent the stray impedance from affecting test accuracy.

5.1.1 Sweep Correction

- 1) Press the menu key [CAL] and the instrument will display the <Correction> page.
- 2) Move the cursor to the Open zone. ON, OFF, [Meas Open] and [DCR Open] will be displayed in the soft key zone.
- 3) Keep the test fixture be in the open status, then press [Meas Open] to execute an open-circuit correction until the prompt information zone displays that open-circuit correction is finished.
- 4) Press ON to turn on the open-circuit correction function.
- 5) Insert the short plate (ST26010) to the test fixture.
- 6) Move the cursor to the Short zone. ON, OFF, [Meas Short] and [DCR Short] will be displayed in the soft key zone.
- 7) Press [Meas Short] to execute the short-circuit correction till the prompt information zone displays that the short-circuit correction is finished.
- 8) Press ON to turn the short-circuit correction function.
- 9) Move the cursor to the Load zone. ON, OFF will be displayed in the soft key zone.
- 10) Press OFF to turn off the load correction function.
- 11) Move the cursor to the Freq zone, ON, OFF, [Meas Open], [Meas Short] and [Meas Load] will be displayed in the soft key zone.
- 12) Press OFF to turn off the point-frequency correction function of Freq.

5.1.2 Point-Frequency Correction

This function will yield better results in a single-frequency test.

If the measurement frequency is 5.5 kHz...

- 1) Press the menu key [CAL] and the instrument will display the <Correction> page.
- 2) Move the cursor to the Freq zone, ON, OFF, [Meas Open], [Meas Short] and [Meas Load] will be displayed in the soft key zone.
- 3) Press ON to turn on the point-frequency correction function of Freq.
- 4) Press the key to input the specified frequency size of 5.5 k. The frequency area will be changed to 5.5000 kHz (the same as the measurement frequency).
- 5) Keep the test fixture open and press [Meas Open] to execute an open-circuit correction.
- 6) Insert the short plate (ST26010) to the test fixture.
- 7) Press [Meas Short] to execute a short-circuit correction.

5.2 Correct Connection of DUT

The instrument has Hcur (current sampling high end Hc), Lcur (current sampling low end Lc), Hpot (voltage sampling high end Hp), Lpot (voltage sampling low end Lp) and a total of four pairs of test terminals corresponding to the shielding end of each test terminal.

Each terminal contains a shielding layer whose function is to reduce the influence of the ground stray capacitance and the interference of the electromagnetic field.

In the process of measuring, Hcur, Hpot and Lpot, Lcur should be connected with DUT lead to form a complete 4-terminal measurement, thus reducing the effect of the lead and the connection points on the measurement results (especially the dissipation measurement). When measuring low-ohm components, Hpot, Lpot should be connected to the lead terminal so as to avoid the impedance being added to the lead impedance; the connection principle is that the Hpot and Lpot test should be the actual existed voltage on DUT.

Note: In other words, before connecting to DUT, it is not recommended to connect Hcur, Hpot with Lpot, Lcur, as doing so will increase test error!

If the connection point and the lead resistance R_{lead} are far weaker than the tested impedance (for example: $R_{lead} < Z_x / 1000$, the accuracy error is required to be less than 0.1 %), before connecting to DUT, it is recommended to connect Hcur, Hpot and Lpot, Lcur (two terminal test).

In a test with a high accuracy requirement, using a Kelvin test fixture (standard accessory) will gain better results than using test leads. When a Kelvin test lead is used under 10 kHz, a better measurement result can be obtained. However, when the frequency is higher than 10 kHz, it cannot meet the measurement demand. At a high frequency, the change of the clearance between test leads will directly change stray capacitance and inductance on test terminals – this problem is unavoidable because the test leads cannot be fixed in a position.

So, at a high frequency, a test fixture should be used if possible. If there is no test fixture available or none can be used, the status of test leads should be the same in the processes of correction and test.

No matter the standard Kelvin test fixture or Kelvin test leads or user-made fixture is used, the following requirements should be met:

Distribution impedance must be reduced to a minimum especially when measuring high impedance components.

Contact resistance must be reduced to a minimum.

Short-circuit and open-circuit must be available between contact points. Open-circuit and short-circuit correction can easily reduce the influence of distribution impedance of the test fixture on measurement. For open-circuit correction, the clearance between test terminals should be the same as that when they connect with DUT. For short-circuit correction, the short plate of low impedance should be connected between test terminals. Another way is to directly connect Hc with Lc or Hp with Lp, then connect both.

Note: When the DUT is a polarity component, before measuring, the high potential terminal should be connected to the terminal with mark "+", "Hc" or "Hp" and the low terminal should be connected to the terminal with mark "-", "Lc" or "Lp".

Warning!



Before measuring, please discharge the tested polarity component so as to avoid the damage to the instrument.

5.3 Eliminate the Influence of Stray Impedance

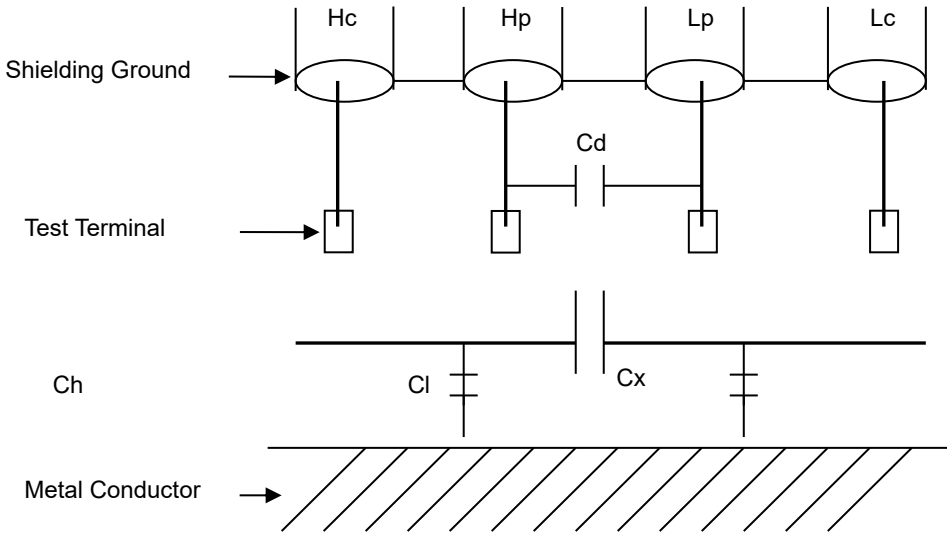

Figure 5-1 Influence of Stray Impedance (Problem)

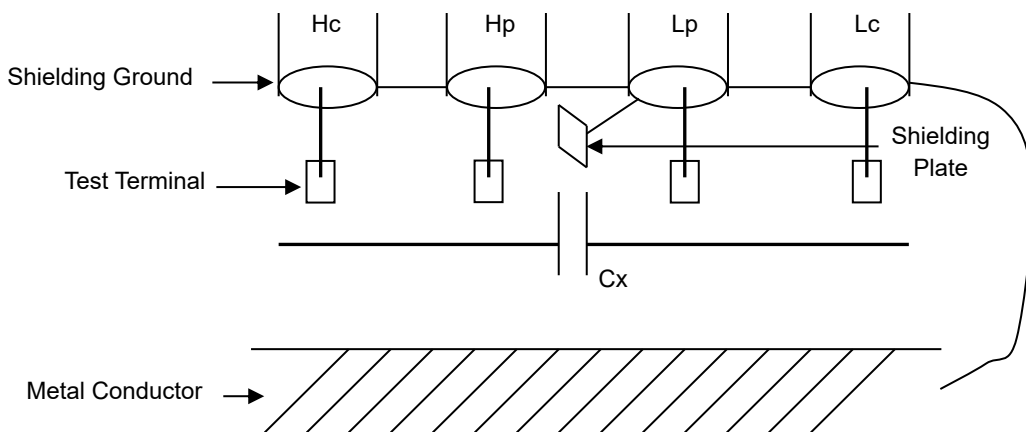

Figure 5-2 Influence of Stray Impedance (Solution)

When the DUT has high impedance (such as small capacitance), the influence of stray capacitance cannot be ignored. Figure 5-1 is an example of the use of 4 terminal pair measurement. In this figure, Cd is connected with Cx in a parallel way and when a conductance plate is positioned under DUT, capacitance Ch will connect with Cx in parallel after connecting with C1 in series; this way the measurement result will have errors. If a ground conductor is installed between high and low terminals, Cd can be reduced to minimum. Meanwhile if the ground terminal is connected to the conductance plate, the influence of Ch and C1 will be eliminated.

When the DUT is low impedance (such as small inductance, large capacitance), a large current will flow through the test leads Hc and Lc. In this case, **electromagnetic coupling between test leads becomes the main source of test errors**, except for the influence of the contact resistance on test terminals. If this coupling cannot be eliminated, it will bring unexpected influence on measurement results.

Generally, contact resistance affects the resistance of impedance and electromagnetic affects the reactance of impedance. Test terminals can adopt a 4-terminal-pair (4TP) connection method.

With a 4TP connection, the currents flow though Hc and Lc are equal in value and opposite in direction compared to those flowing through each shielding terminals (the current reflow from Hc to shielding layer). This way, the magnetic fields produced by these currents can be mutually offset and further eliminate the influence of mutual inductance coupling on measurement results.

5.4 Example: Testing Inductance

5.4.1 Measurement Settings

Function: Ls-Q

Frequency: 5.5 kHz

Level: 1.5 V_{rms}

Internal impedance: 100 Ω

5.4.2 Operation Steps

- 1) Turn on the instrument.
- 2) Set basic parameters.
- 3) Press [DISP] to enter into the <Meas Display> page.
- 4) Move the cursor to the Parameter area, the optional parameters are in the soft key area on the right side of the screen.
- 5) Press Ls to select Ls measurement function.
- 6) Move the cursor to Freq, the current frequency is 1.0000 kHz. The frequency can be modified as needed.
- 7) Move the cursor to Level, the current displayed level will be 1.000 V.
- 8) Press [SETUP] to enter into the <Meas Setup> page.
- 9) Move the cursor to R_{SOU} zone, 100 Ω and 30 Ω will be displayed in the soft key zone.
- 10) Press 100 Ω to select 100 Ω as the signal internal impedance.
- 11) Connect the test fixture (ST26005) to the test terminals.
- 12) Perform a correction (to avoid the influence of stray impedance on measurement accuracy, an open-circuit/short-circuit correction is needed)
- 13) Mount the tested inductance to the test fixture.
- 14) Execute test operation.
- 15) Press [DISP] to enter into the <Meas Display> page. The instrument will continuously test and put the measurement result in the center of the page.

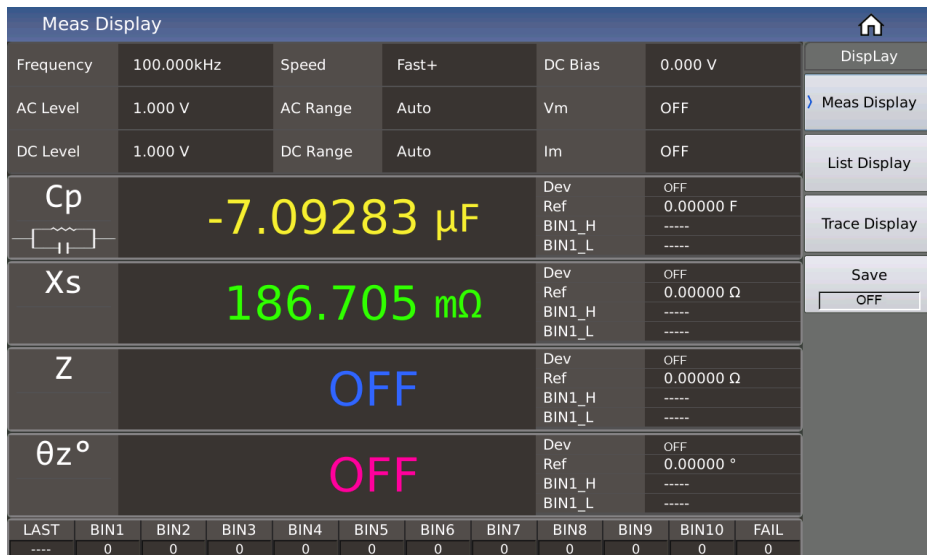

- 16) If the measurement result is obviously incorrect, please check the following items.
- Check the tested inductance is in good connection with the test fixture or not.
 - Check the test fixture is in good connection with the test terminals of the instrument or not.
 - Redo the open-circuit/short-circuit correction.

Note: When the sweep open-circuit/short-circuit correction is used, the point-frequency correction should be set to OFF.

5.5 Example: Testing Capacitance by Multi-Frequency List Sweep

5.5.1 Measurement Settings

Function: Cp, D

Level: 1 Vrms

Other Parameters:

Frequency	Comparison Parameter	Low Limit	High Limit
1 kHz	Cp (capacitance)	325.0 nF	333.0 nF
10 kHz	D (dissipation)	0.0001	0.0003
100 kHz	D (dissipation)	0.0060	0.0100

Sound: High Long

Alarm Mode: OFF

5.5.2 Operation Steps

Turn on the instrument.

Configure Basic Parameters:

- Press [DISP] to enter into the <Meas Display> page.
- The Parameter zone is currently displayed as Cp, D and the Level zone is 1.000 V.
- Press [SETUP] to enter into the <Meas Setup> page, meanwhile the following soft keys will be displayed in the soft key zone: [Meas Setup], [User Corr], [Limit Setup], [List Setup] and [FILE].
- Press the [List Setup] button to enter into the <List Setup> page.
- Press the knob to move the cursor to the parameter area of sweep point 1, modify the measurement conditions of the current point, including Frequency, Level, Bias, Limit, Delay, etc.

Sound Setup:

- Press [SYSTEM] to enter into the <System Setup> page.
- Move the cursor to the Fail Sound zone to select [High Long].
- Mount the test fixture (ST26005) to the test terminals of the tester.
- Execute correction function (to avoid the influence of the stray impedance on the measurement accuracy, an open-circuit/short-circuit correction is needed).
- Insert the tested capacitor to the test fixture.

Execute Test Operations:

Press [DISP] and then [List Sweep] to enter into the <List Sweep Display> page. The instrument will test continuously and then display the test and the comparison results on page. If the comparison result is PASS or FAIL, there is a sound alarm.

List Display									Display
Pt	Freq	Level	Bias	Para1	Para2	Para3	Para4	P/F	
1	1.00000kHz	1.00000 V	0.00000 A	Cp=-22.9015pF	Cp=-22.9015pF	Cp=-22.9015pF	Cp=-22.9015pF	---	Meas Display
2	1.00000kHz	1.00000 V	0.00000 A	Cp=-22.9015pF	Cp=-22.9015pF	Cp=-22.9015pF	Cp=-22.9015pF	---	List Display
3	1.00000kHz	1.00000 V	0.00000 A	Cp=-22.9015pF	Cp=-22.9015pF	Cp=-22.9015pF	Cp=-22.9015pF	---	Trace Display
4	1.00000kHz	1.00000 V	0.00000 A	Cp=-22.9015pF	Cp=-22.9015pF	Cp=-22.9015pF	Cp=-22.9015pF	---	Save
5	1.00000kHz	1.00000 V	0.00000 A	Cp=-22.9015pF	Cp=-22.9015pF	Cp=-22.9015pF	Cp=-22.9015pF	---	OFF
6	1.00000kHz	1.00000 V	0.00000 A	Cp=-22.9015pF	Cp=-22.9015pF	Cp=-22.9015pF	Cp=-22.9015pF	---	
7	1.00000kHz	1.00000 V	0.00000 A	Cp=-22.9015pF	Cp=-22.9015pF	Cp=-22.9015pF	Cp=-22.9015pF	---	
*8	1.00000kHz	1.00000 V	0.00000 A	Cp=-22.9015pF	Cp=-22.9015pF	Cp=-22.9015pF	Cp=-22.9015pF	---	

If the measurement result is obviously incorrect, please check the following items:

- Check the tested inductance is in good connection with the test fixture or not.
- Check the test fixture is in good connection with the test terminals of the instrument or not.
- Redo the open-circuit/short-circuit correction.

Note: When the sweep open-circuit/short-circuit correction is used, the point-frequency correction function should be set to OFF.

5.6 Example: Load Correction

5.6.1 Measurement Settings

Assume the following measurement conditions:

Frequency: 100 kHz

Cp Standard Value: 11 nF

D Standard Value: 0.0005

5.6.2 Operation Steps

- Press [CAL], the instrument will display the <User Corr> page.
- Move the cursor to Load, the following soft keys will be displayed in the soft key zone: ON and OFF.
- Press ON to turn on the load correction function.
- Move the cursor to Load Type, [Ls-Rs], [Ls-Q], [Cp-D] will be displayed in the soft key area on the right side of the screen.
- Press [Cp-D] to select the Cp-D function.
- Move the cursor to Freq zone, the following soft keys will be displayed in the soft key zone: ON, OFF, [Open], [Short] and [Load].

- 7) Press ON to turn on the point-frequency correction function of the corresponding Freq in current correction point.
- 8) Input the correction frequency (100k), reference A (11 nF), reference B (0.0005)
- 9) Move the cursor to Freq zone, the following soft keys will be displayed in the soft key zone: ON, OFF, [Open], [Short] and [Load].
- 10) Hold the test fixture be in open status and keep user's hands or other interference source be far away from the test fixture. Press the soft key [Open] to execute an open-circuit correction.
- 11) Insert the short plate (ST26010) into the test fixture. Please ensure that the short plate and the reeds of the test fixture have good contact.
- 12) Press the soft key [Short] to execute a short-circuit correction.
- 13) Insert a standard capacitance into the test fixture. Please ensure that the pins of the standard capacitance have good connection with the reeds of the test fixture.
- 14) Press the soft key [Load] to execute a load correction.

Note: Due to different software versions, the soft keys and status information may be slightly different from the way it is referenced in this manual, but this should not affect your general understanding of the processes.

The load correction is only valid for the components with the same specification. If the specification is changed, the load correction must be redone.

6 Performance and Test

6.1 Measurement Function

6.1.1 Parameters

Parameter Name	Parameter Meaning	Parameter Name	Parameter Meaning
Cp	Equivalent Parallel Capacitance	Cs	Equivalent Series Capacitance
Lp	Equivalent Parallel Inductance	Ls	Equivalent Series Inductance
Rp	Equivalent Parallel Resistance	Rs	Equivalent Series Resistance
Gp	Conductance	Bp	Susceptance
Z	Absolute Value Of Impedance	Y	Absolute Value Of Admittance
D	Loss Factor	Q	Quality Factor
θ_z°	Impedance Degree	θ_z	Impedance Radian
θ_y°	Admittance Degree	θ_y	Admittance Radian
X	Reactance	Rd	DC Resistance

6.1.2 Measurement Combination

Four parameters can be selected freely, regardless of primary and secondary parameters.

6.1.3 Mathematical Operation

Operation between the measurement value and the programmable nominal value:

- Absolute Deviation Δ ABS
- Percent Deviation $\Delta\%$

6.1.4 Equivalent Mode

- Series
- Parallel

6.1.5 Range

- Auto
- Manual (hold, increase and decrease)

6.1.6 Trigger Mode

Single Trigger Mode: Press the [TRIGGER] key on the panel, have the Handler Interface of the instrument receive an external start signal, use the foot switch or use the bus trigger command to make the instrument perform a single measurement and output the result and display it, usually in a waiting state.

Continuous Trigger Mode: Continuously measure the DUT and output the results for display.

6.1.7 Delay Time

Trigger Delay: The time between the trigger and the beginning of the measurement. 0 ~ 60 s; programmable; 1 ms resolution

Step Delay: The delay time before the measurement signal is output to the measurement. 0 ~ 60 s; programmable; 1 ms resolution.

6.1.8 Connection Modes of Test Terminals

ST2840 adopts a 4-terminal measurement method:

- **Hcur:** Current sample high terminal
- **Lcur:** Current sample low terminal
- **Hpot:** Voltage sample high terminal
- **Lpot:** Voltage sample low terminal

6.1.9 Measurement Speed (Frequency \geq 10 kHz)

Fast+: about 1800 measurements / s (0.55 ms / measurement)

Fast: about 300 measurements / s (3.3 ms / measurement)

Medium: about 11 measurements / s (90 ms / measurement)

Slow: about 4 measurements / s (240 ms / measurement)

The fast+, fast and medium speed will slow down when the frequency is below 10 kHz.

6.1.10 Average

255; programmable.

6.1.11 Digits Displayed

6 digits; with a max. display of 999999.

6.2 Measurement Signal

6.2.1 Measurement Signal Frequency

The measurement signal is a sine wave.

Accuracy: 0.01 %

Frequency Range:

- 20 Hz ~ 500 kHz (ST2840A)
- 20 Hz ~ 2 MHz (ST2840B)

Min. Resolution: 1 mHz

6.2.2 Signal Mode

Normal: During measuring, the voltage across test terminals may be less than the preset voltage on the measurement display page.

Constant Level: Internal auto adjustment ensures the voltage of DUT corresponds with preset voltage.

6.2.3 Measurement Signal Level

	Mode	Freq	Range	Accuracy	Resolution
Voltage	Normal	≤ 1 MHz	5 mV _{rms} ~ 20 V _{rms}	$\pm 10 \% \times (\text{preset value} + 2 \text{ mV})$	100 μ V
	Constant Level	> 1 MHz	5 mV _{rms} ~ 15 V _{rms}	$\pm 6 \% \times (\text{preset value} + 2 \text{ mV})$	
Current	Normal	20 ~ 2 MHz	50 μ A _{rms} ~ 100 mA _{rms}	$\pm 10 \% \times (\text{preset value} + 10 \mu\text{A}_{\text{rms}})$	1 μ A
	Constant Current				

6.2.4 Output Impedance

Choose between 30 $\Omega \pm 4 \%$ or 100 $\Omega \pm 2 \%$.

6.2.5 Monitor for Measurement Signal Level

	Frequency	Range	Accuracy
Voltage	≤ 1 MHz	5 mV _{rms} ~ 20 V _{rms}	$\pm (3 \% \times \text{reading} + 0.5 \text{ mV})$
	> 1 MHz	5 mV _{rms} ~ 15 V _{rms}	$\pm (6 \% \times \text{reading} + 0.5 \text{ mV})$
Current	≤ 1 MHz	50 μ A _{rms} ~ 100 mA _{rms}	$\pm (3 \% \times \text{reading} + 5 \mu\text{A})$
	> 1 MHz	50 μ A _{rms} ~ 100 mA _{rms}	$\pm (6 \% \times \text{reading} + 5 \mu\text{A})$

6.2.6 Maximum Measurement Display Range

Parameter	Display Range
L, Lk	0.00001 μ H ~ 99.9999 kH
C	0.00001 pF ~ 9.99999 F
Z, R, X, DCR	0.00001 Ω ~ 99.9999 M Ω
Y, B, G	0.00001 μ s ~ 99.9999 s
D	0.00001 ~ 9.99999
Q	0.00001 ~ 99999.9
θ	Deg -179.999 ~ 179.999 Rad -3.14159 ~ 3.14159
Turns Ratio	(1 : 0.001) ~ (1000 : 1)

6.2.7 DC Bias Voltage Source

Range	Resolution	Accuracy
0 ~ \pm 40 V	1 mV	1 % \times preset voltage + 5 mV
0 ~ \pm 100 mA	10 μ A	–

6.2.8 2A Bias Current Source

Range	Resolution	Accuracy (I > 5 mA)
0 ~ 2 A	1 mA	\pm (2 % \times set value + 2 mA)

6.3 Measurement Accuracy

Measurement accuracy includes:

- Stability
- Temperature Coefficient
- Linear Degree
- Test Repeatability
- Calibration Inter-Error

Any examination of the instrument's accuracy should be under the following circumstances:

- **Warm-Up Time:** \geq 60 min
- **Cable Length:** 0 m, 1 m
- Open-circuit and short-circuit correction after warming up.
- DC bias is turned OFF.
- The range is set to AUTO to select the correct measurement range.

6.3.1 Accuracy of $|Z|$, $|Y|$, L, C, R, X, G, B

The accuracy A_e of $|Z|$, $|Y|$, L, C, R, X, G and B is expressed as:

$$A_e = \pm [A_L \times A + (K_a + K_b + K_c) \times 100 + K_d + K_f] \times K_e \quad [\%]$$

- A: Basic Measurement Accuracy (Figure 6-1)
- A_L : Level Correction Factor (Table 6-1)
- K_a : Impedance Rate Factor (Table 6-2; Table 6-3)
- K_b : Impedance Rate Factor (Table 6-2; Table 6-4)
- K_c : Calibrated Interpolating Factor (Table 6-5)
- K_d : Cable Length Factor (Table 6-7)
- K_e : Temperature Factor (Table 6-8)
- K_f : Scan Fixture Modification Factor (no scan fixture: $K_f = 0$; scan fixture: $K_f = 0.2$)
- L, C, X, B Accuracy A_e , using condition: D_x (test value of D) ≤ 0.1
- R, G Accuracy A_e , using condition: Q_x (test value of Q) ≤ 0.1

When $D_x \geq 0.1$, the accuracy factor A_e of L, C, X, B is to be multiplied by $\sqrt{1 + D_x^2}$

When $Q_x \geq 0.1$, the accuracy factor A_e of R, G is to be multiplied by $\sqrt{1 + Q_x^2}$

6.3.2 Accuracy of D

The accuracy of D is defined as:

$$D_e = \pm \frac{A_e}{100}$$

This formula is only available when $D_x \leq 0.1$. When $D_x > 0.1$; D_e should be multiplied by $(1 + D_x)$.

6.3.3 Accuracy of Q

The accuracy of Q is defined as:

$$Q_e = \pm \frac{Q_x^2 \times D_e}{1 + Q_x \times D_e}$$

Where...

- Q_x is the value of the tested Q;
- D_e is the accuracy of D.

The formula should be used when $Q_x \times D_e < 1$.

6.3.4 Accuracy of Θ

The accuracy of θ is defined as:

$$\theta_e = \frac{180}{\pi} \times \frac{A_e}{100} \quad [\text{deg}]$$

6.3.5 Accuracy of G

When D_x (value of the tested D) ≤ 0.1 , the accuracy of G is defined as:

$$G_e = B_x \times D_e \quad [\text{S}]$$

$$B_x = 2\pi f C_x = \frac{1}{2\pi f L_x}$$

Where...

- B_x is the value of the tested B with the unit [S];
- C_x is the value of the tested C with the unit [F];
- L_x is the value of the tested L with the unit [H];
- D_e is the accuracy of D;
- F is the measurement frequency.

6.3.6 Accuracy of R_p

When D_x (value of the tested D) ≤ 0.1 , the accuracy of R_p is defined as:

$$R_{pe} = \pm \frac{R_{px} \times D_e}{D_x \mp D_e} \quad [\Omega]$$

Where...

- R_{px} is the value of the tested R_p with the unit [S];
- D_x is the value of the tested D with the unit [F];
- D_e is the accuracy of D.

6.3.7 Accuracy of R_s

When D_x (value of the tested D) ≤ 0.1 , the accuracy of R_s is defined as:

$$R_s = X_x \times D_e \quad [\Omega]$$

$$X_x = 2\pi f L_x = \frac{1}{2\pi f C_x}$$

Where...

- X_x is the value of the tested X with the unit [S];
- C_x is the value of the tested C with the unit [F];
- L_x is the value of the tested L with the unit [H];
- D_e is the accuracy of D;
- F is the measurement frequency

6.3.8 Accuracy of DCR

$$A (1 + R_x / 5 \text{ M}\Omega + 16 \text{ m}\Omega / R_x) [\%] \pm 0.2 \text{ m}\Omega$$

At medium and slow measurement speed, $A = 0.25$; at fast measurement speed, $A = 0.5$.

Here, R_x is the measured resistance.

6.3.9 Accuracy of Lk

$$\text{Inductance L accuracy} + 0.2 \%$$

6.3.10 Accuracy of Turns Ratio

$$\pm A_t \times A_r (1 + 1 \Omega / Z_p + 1 / Q) [\%] \pm 0.002$$

At medium and slow measurement speed, $A_t = 0.25$; at fast measurement speed, $A_t = 0.5$

Where...

- Z_p is the impedance of the measured primary inductance;
- A_r is the correction value of the measurement signal accuracy in Figure B.

This accuracy index is used when the coupling coefficient of the transformer under test is 1 or close to 1.

6.3.11 Accuracy Factor

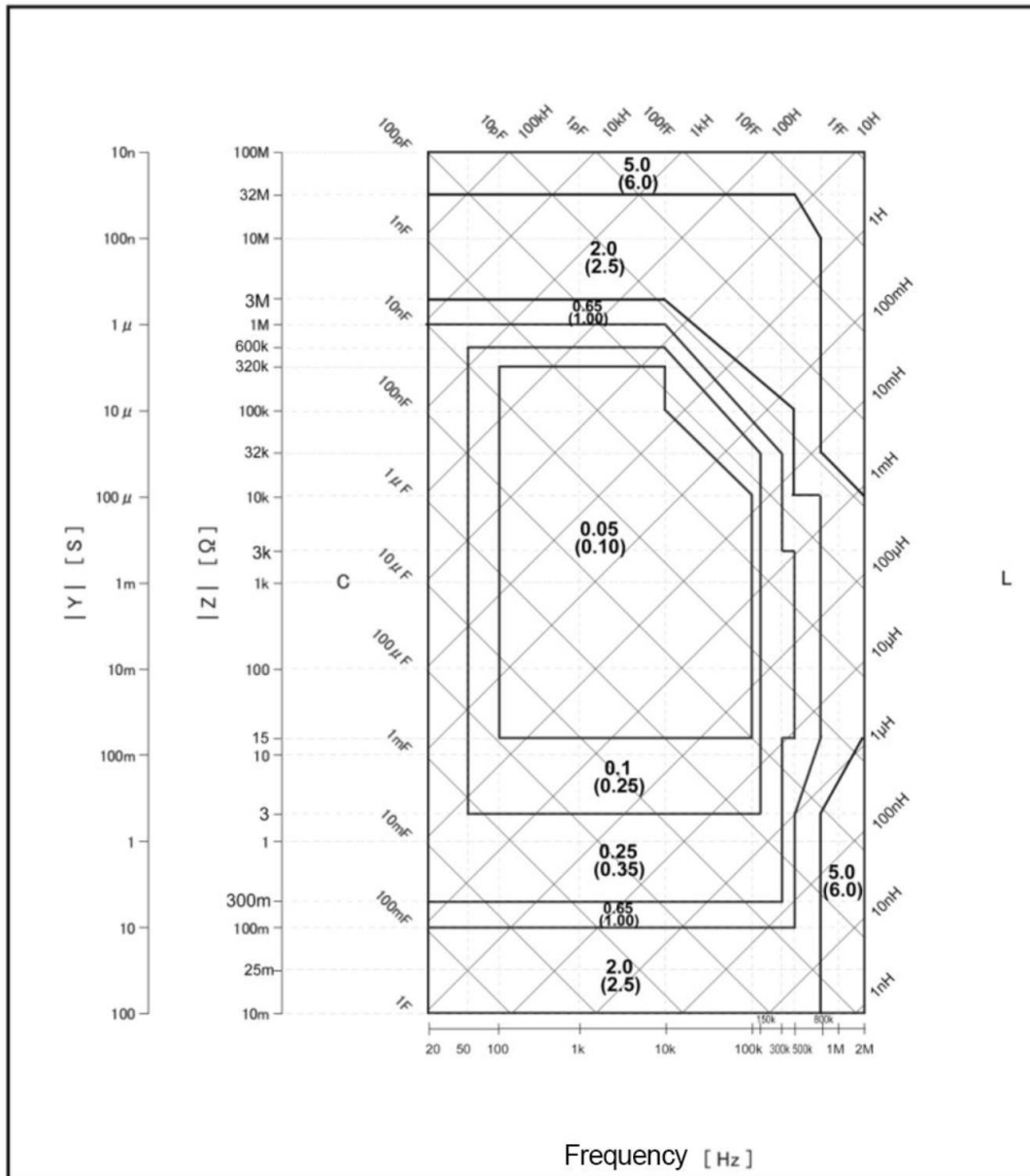

Figure 6-1 Basic Measurement Accuracy Factor A

The basic accuracy A can be read from the diagram as follows:

Determine the intersection point of the straight line corresponding to the expected measured value with the measuring frequency. Two numbers are assigned to the outlined subarea in which this crossing point is located. At slow and medium measurement speeds the upper and at fast measurement speeds the lower of the two numbers is the value of A we are looking for.

The basic measurement accuracy factor A is applicable to a measurement level range of 500 mV_{rms} ~ 1.0 V_{rms}. When exceeding this range, determine A as outlined above, then select the value of A_L according to the table below. The final value is then obtained by calculating A_L × A.

Here, V_s is the measurement signal voltage.

Note: If all of the following measurement conditions are met, the A value is increased by 0.15.

- **Test Frequency:** 100 Hz < f_m ≤ 2 MHz
- **Test Signal Voltage:** 5 V_{rms} < V_s ≤ 20 V_{rms}
- **DUT:** Inductor, |Z_m| < 200 Ω (|Z_m| : DUT impedance)

Table 6-1 Correction Factor A_L

Measurement Signal Voltage V_s (V_{rms})						
V_s (V_{rms})	[5 m, 50 m]	(50 m, 200 m]	(200 m, 500 m]	(500 m, 1]	(1, 2]	(2, 20]
A_L	$2.5 \times 50 \text{ mV}_{rms} / V_s$	2.5	$500 \text{ mV}_{rms} / V_s$	1	V_s	4

Table 6-2 Impedance Rate Factors K_a and K_b

Speed	Frequency	K_a	K_b
Medium Slow	$f_m \leq 1.2 \text{ kHz}$	$\left(\frac{1 \times 10^{-3}}{ Z_m }\right)\left(1 + \frac{200}{V_s}\right)\sqrt{\frac{100}{f_m}}$	$ Z_m (0.3 \times 10^{-9})\left(1 + \frac{70}{V_s}\right)\sqrt{\frac{100}{f_m}}$
	$1.2 \text{ kHz} < f_m \leq 8 \text{ kHz}$	$\left(\frac{1 \times 10^{-3}}{ Z_m }\right)\left(1 + \frac{200}{V_s}\right)$	$ Z_m (1 \times 10^{-9})\left(1 + \frac{70}{V_s}\right)$
	$8 \text{ kHz} < f_m \leq 150 \text{ kHz}$		$ Z_m (3 \times 10^{-9})\left(1 + \frac{70}{V_s}\right)$
	$150 \text{ kHz} < f_m \leq 1 \text{ MHz}$	$\left(\frac{1 \times 10^{-3}}{ Z_m }\right)\left(3 + \frac{200}{V_s}\right)$	$ Z_m (10 \times 10^{-9})\left(1 + \frac{70}{V_s}\right)$
Fast	$f_m \leq 1.2 \text{ kHz}$	$\left(\frac{2.5 \times 10^{-3}}{ Z_m }\right)\left(1 + \frac{400}{V_s}\right)\sqrt{\frac{100}{f_m}}$	$ Z_m (0.6 \times 10^{-9})\left(1 + \frac{100}{V_s}\right)\sqrt{\frac{100}{f_m}}$
	$1.2 \text{ kHz} < f_m \leq 8 \text{ kHz}$	$\left(\frac{2.5 \times 10^{-3}}{ Z_m }\right)\left(1 + \frac{400}{V_s}\right)$	$ Z_m (2 \times 10^{-9})\left(1 + \frac{100}{V_s}\right)$
	$8 \text{ kHz} < f_m \leq 150 \text{ kHz}$		$ Z_m (6 \times 10^{-9})\left(1 + \frac{100}{V_s}\right)$
	$150 \text{ kHz} < f_m \leq 1 \text{ MHz}$	$\left(\frac{2.5 \times 10^{-3}}{ Z_m }\right)\left(2 + \frac{400}{V_s}\right)$	$ Z_m (20 \times 10^{-9})\left(1 + \frac{100}{V_s}\right)$

Where...

- f_m is the measurement frequency; its unit is [Hz];
- The unit of the tested impedance is [Ω];
- The unit of the measurement signal voltage is [mV_{rms}].

For impedances above 500 Ω , K_a is negligible, and only K_b is used; for impedances below 500 Ω , K_b is negligible, and only K_a is used.

Note: When the cable length is extended, K_a should have the following value added.

Table 6-3 Added Values to K_a Based on Cable Length L

Cable Length L [m]	Added Value to K_a
0	0
1	0.0005
2	0.0010

Note: At the same time, when the cable length is extended, K_b should be multiplied the following value.

Table 6-4 Multiplied Values to K_b Based on Cable Length

Cable Length L [m]	$f_m \leq 100 \text{ kHz}$	$100 \text{ kHz} < f_m \leq 300 \text{ kHz}$	$300 \text{ kHz} < f_m \leq 1 \text{ MHz}$
0	1	1	1
1	$1 + 5 \times f_m$	$1 + 2 \times f_m$	$1 + 0.5 \times f_m$
2	$1 + 10 \times f_m$	$1 + 4 \times f_m$	$1 + 1 \times f_m$

Here, f_m is the measurement frequency and its unit is [MHz].

The calibration correction data are linearly interpolated between the measured frequency points (Table 6-5). The interpolation correction factor K_c indicates the deviation between the interpolated data and the real measurement deviation between the calibration points.

Table 6-5 Calibrated Interpolating Factor K_c

Measurement Frequency	K_c
Direct calibrated frequency (listed in Table 6-6)	0
Other frequency	0.0003

Table 6-6 Direct Calibrated Frequency

			20	25	30	40	50	60		80		[Hz]
100	120	150	200	250	300	400	500	600		800		[Hz]
1	1.2	1.5	2	2.5	3	4	5	6		8		[kHz]
10	12	15	20	25	30	40	50	60		80		[kHz]
100	120	150	200	250	300	400	500	600	700	800	900	[kHz]
1	1.1	1.2	1.3	1.4	1.5	1.6	1.7	1.8	1.9	2		[MHz]

Note: There are 60 frequencies listed in Table 6-6. The highest frequency of ST2840A is up to 500 kHz and the highest frequency of ST2840B is up to 2 MHz.

Table 6-7 Cable Length Factor K_d

Measurement Signal Level	Cable Length L		
	1 m	2 m	4 m
$\leq 2 V_{rms}$	$2.5 \times 10^{-4} (1 + 50 \times f_m)$	$5 \times 10^{-4} (1 + 50 \times f_m)$	$1 \times 10^{-3} (1 + 50 \times f_m)$
$> 2 V_{rms}$	$2.5 \times 10^{-3} (1 + 16 \times f_m)$	$5 \times 10^{-3} (1 + 16 \times f_m)$	$1 \times 10^{-2} (1 + 16 \times f_m)$

Here, f_m is the measurement frequency and its unit is [MHz].

Table 6-8 Temperature Factor K_e

Temperature	K_e
0 ~ 18 °C	4
18 ~ 28 °C	1
28 ~ 40 °C	4

6.4 Performance Testing

6.4.1 Operating Conditions

All measurements should take place under the specific operating conditions listed in this manual, including an appropriate warm-up time (see Chapter 1.6). Only primary indexes are listed in this section.

6.4.2 Used Instruments and Devices

No.	Instrument/Device		Specification
1	Standard Capacitor	100 pF	0.02 % D is known
		1000 pF	
		10000 pF	
		10 nF	
		0.1 μ F	
		1 μ F	
2	AC Standard Resistor	10 Ω	0.02 %
		100 Ω	
		1 k Ω	
		10 k Ω	
		100 k Ω	
3	DC Standard Resistor	0.1 Ω	0.02 %
		1 Ω	
		10 Ω	
		100 Ω	
		1 k Ω	
		10 k Ω	
		100 k Ω	
4	Standard Inductor	100 μ H	0.02 %
		1 mH	
		10 mH	
		100 mH	
5	Frequency Counter		(0 ~ 1000) MHz
6	Digital Multimeter		0.5 %
7	Insulation Resistance Meter		500 V; 10 levels
8	High Voltage Tester		0.25 kW (0 ~ 500) V

6.4.3 Basic Functionality Check

Ensure that function keys, display, interfaces, etc. are operating normally.

6.4.4 Check the Signal Level

Connect a multimeter in the AC voltage setting between Hcur and the ground. Set the measurement level to 10 mV, 20 mV, 100 mV, 200 mV, 1 V, 2 V, 10 V and 20 V, and check that the reading is within the limits given in this chapter.

6.4.5 Check the Frequency

Connect a frequency meter between the ground terminal and Hcur. Set the frequency to 20 Hz, 100 Hz, 1 kHz, 10 kHz, 100 kHz, 200 kHz, 500 kHz, 1 MHz and 2 MHz, and check that the reading is within the limits given in this chapter.

6.4.6 Check the Measurement Accuracy

R, L, C and D are the basic parameters, therefore the measurement accuracy is mainly defined by them.

6.4.6.1 Accuracy of C and D

Function	Measurement Frequency (test each respectively)	Level	Range	Bias	Speed
C _p -D	<ul style="list-style-type: none"> • 100 Hz • 1 kHz • 10 kHz • 100 kHz 	1 V	AUTO	0 V	Slow

Open-circuit and short-circuit correction should be performed before measurement. Connect your standard capacitors of 100 pF, 1000 pF, 10 nF, 0.1 μF and 1 μF and measure them at the different frequencies. Check that the deviation between the readings and the standard values of C and D is within the limits given in this chapter.

6.4.6.2 Accuracy of L

Function	Measurement Frequency (test each respectively)	Level	Range	Bias	Speed
L _s -Q	<ul style="list-style-type: none"> • 100 Hz • 1 kHz 	1 V	AUTO	0 V	Slow

Open-circuit and short-circuit correction should be performed before measurement. Connect your standard inductors of 100 μH, 1 mH, 10 mH and 100 mH and measure them at the different frequencies. Check that the deviation between the reading and the standard value of L is within the limits given in this chapter.

6.4.6.3 Accuracy of Z

Function	Measurement Frequency (test each respectively)	Level	Range	Bias	Speed
Z- θ	<ul style="list-style-type: none"> • 100 Hz • 1 kHz • 10 kHz • 100 kHz 	1 V	AUTO	0 V	Slow

Open-circuit and short-circuit correction should be performed before measurement. Connect your AC standard resistors of 10 Ω , 100 Ω , 1 k Ω , 10 k Ω and 100 k Ω and measure them at the different frequencies. Check that the deviation between the reading and the standard value of $|Z|$ is within the limits given in this chapter.

6.4.6.4 Accuracy of DCR

Function	Measurement Frequency	Level	Range	Bias	Speed
DCR	–	–	AUTO	–	Slow

Short-circuit correction should be performed before measurement. Connect your DC standard resistors of 0.1 Ω , 1 Ω , 10 Ω , 100 Ω , 1 k Ω , 10 k Ω and 100 k Ω and measure them at the different frequencies. Check that the deviation between the reading and the standard value of DCR is within the limits given in this chapter.

7 Command Reference

7.1 GPIB Common Commands

- *RST
- *TRG
- *IDN
- *TST
- *ESE
- *SRE
- *ESR
- *STB
- *OPC
- *CLS

The ***RST** command resets the instrument.

For example: WrtCmd ("*RST")

The ***TRG** command triggers the measurement and then sends the result.

For example: WrtCmd ("*TRG")

Test Page			
LCR Meter	Component Testing	Parameter 1 result, parameter 2 result, parameter 3 result, parameter 4 result, the sorting results. Example: 1.12345E2, 1.23456E-2, 1.11023E2, -1.12345E2,1 The sorting results take the following values:	
		Sorting Results	Description
		0	BIN OUT
	1 ~ 10	BIN 1 ~ 10	
	Note: The <BIN> data will only be displayed when the comparison function is turned ON.		
	List Sweep	Single-Step	Clike index, parameter 1 result, parameter 2 result, parameter 3 result, parameter 4 result, the comparison results. Example: 2,1.12345E2,1.23456E-2,1.11023E2,-1.12345E2,1 The comparison results take the following values:
Comparison Results			Description
0			No Comparison
1		PASS	
Other	FAIL		
Sequential	Data will be returned after all points have been tested. The data format is the same as above.		
Trace Sweep	Single-Step	Clike index, parameter 1 result, parameter 2 result, parameter 3 result, parameter 4 result. Example: 2, 1.12345E2, 1.23456E-2, 1.11023E2, -1.12345E2	
	Sequential	Data will be returned after all points have been tested. The data format is the same as above.	

The *IDN? query returns the instrument ID.

Query Syntax: *IDN?

Return Format: <model>, <firmware>, <sn>, <date>

Where...

- <model> Instrument Model (ST2840)
- <firmware> Firmware Version (VER1.0.0)
- <sn> Instrument serial number (sn12345678)
- <date> Software release date (e.g. 2024-03-14)

7.2 SCPI Command

SCPI (Standard Command for Programmable Instruments) is an ASCII-based instrument command language used in test and measurement instruments. SCPI commands are based on a hierarchical structure (also known as a tree system).

In this system, related commands are grouped under a common node or root, thus forming a subsystem.

According to the command syntax, most commands (and some parameters) are represented by a mixture of uppercase and lowercase letters. Uppercase letters indicate the abbreviation of the command.

For shorter program lines, you can send commands in abbreviated format; if you want better program readability, you can send long format commands.

Note: To avoid misunderstanding of abbreviations, the command descriptions will avoid excessive abbreviations as much as possible. Most of the command descriptions are given directly in abbreviated form.

Grammatical Conventions:

[SOURce[1|2]:]VOLTage:UNIT {VPP|Vrms|DBM}

[SOURce[1|2]:]FREQuency:CENTer {<frequency>|MINimum|MAXimum|DEFault}

Note: Command Syntax Conventions

Braces (curly brackets) { } contain the parameter options for the given command string. Braces are not sent with the command string.

A vertical bar | separates multiple parameter selections for a given command string. For example, in the above command, {VPP|Vrms|DBM} means you can specify "VPP", "Vrms" or "DBM". The bars are not sent with the command string.

- The angle brackets < > in the second example indicate that you must specify a value for the parameter inside these brackets. For example, in the above syntax statement, the parameter in angle brackets is <frequency>. Angle brackets are not sent with the command string. You must specify a value for the parameter (for example "FREQ: CENT 1000") unless you choose another option (such as "FREQ: CENT MIN") that appears in the syntax.
- Some syntax elements (such as nodes and parameters) are enclosed in square brackets []. This means that the element is optional and can be omitted. Square brackets are not sent with the command string. If no value is specified for the optional parameter, the instrument will choose the default value. In the above example, "SOURce[1|2]" means that you can refer to source channel 1 by "SOURce" or "SOURce1", or "SOUR1" or "SOUR". Also, since the entire SOURce node is optional (in square brackets), you can also refer to channel 1 by completely omitting the SOURce node. This is because channel 1 is already the default channel for the SOURce language node. On the other hand, to refer to channel 2, you must use "SOURce2" or "SOUR2" in the program line.

The abbreviations and shorthands used in this manual are as follows:

- **NR1**: integer, e.g.:123
- **NR2**: fix-point number, e.g.: 12.3
- **NR3**: floating-point number, e.g.: 12.3E+5
- **NL**: carriage key, integer: 10
- **^END**: EOI signal in IEEE-488

Subsystem commands of this series of instruments:

- DISPlay
- ORESister
- TRIGger
- CORRection
- FREQuency
- BIAS
- INITiate
- COMParator
- VOLTage
- FUNCtion
- FETCh?
- Mass MEMory
- CURRent
- LIST
- ABORT
- TRAN
- AMPLitude
- APERture
- STATus

7.2.1 DISPlay Subsystem Commands

Used to control page switching.

Command Syntax:

:DISP:PAGE?

:DISP:PAGE <PageName>

Parameter: The meaning of the value of PageName is shown in the following table.

Page Name	Meaning	Query Return Content
MEASurement	Measurement Display	MEASurement
LIST	List Display	LIST
TSMEas	Trace Sweep Display	TSMEas
MSETup	Measurement Setup	MSETup
LTABLE	Limit Setup	LTABLE
LSETup	List Setup	LSETup
TSSETup	Trace Setup	TSSETup
CSETup	Correction Setup	CSETup
SYSTem	System Setup	SYSTem
FLISt	File List	FLISt

Example:

:DISP:PAGE MEAS Enter the measurement display page;
 :DISP:PAGE MSET Enter the measurement setup page;
 :DISP:PAGE? Return the currently displayed page, please refer to the table above.

7.2.2 FREQUENCY Subsystem Commands

Used to set the measurement frequency of the instrument.

Command Syntax:

:FREQ?
 :FREQ <float | MIN | MAX>

Parameter:

float Represents the floating-point data
 MIN Set the minimum possible value
 MAX Set the maximum possible value

Example:

:FREQ 1200 Set the frequency to 1200 Hz
 :FREQ 1200Hz Set the frequency to 1200 Hz
 :FREQ 1.2k Set the frequency to 1200 Hz
 :FREQ? Return the current frequency

7.2.3 VOLTage Subsystem Commands

7.2.3.1 AC Voltage

Used to set the AC voltage of the instrument.

Command Syntax:

:VOLT?

:VOLT <float | MIN | MAX>

Parameter:

float	Represents the floating-point data
MIN	Set the minimum possible value
MAX	Set the maximum possible value

Example:

:VOLT 1.2 Set the AC voltage to 1.2 V

:VOLT? Return the current AC voltage

7.2.3.2 DC Voltage

Used to set the DC voltage of the instrument.

Command Syntax:

:VOLT:DC?

:VOLT:DC <float | MIN | MAX>

Parameter:

float	Represents the floating-point data
MIN	Set the minimum possible value
MAX	Set the maximum possible value

Example:

:VOLT:DC 1.2 Set the DC voltage to 1.2 V

:VOLT:DC? Return the current DC voltage

7.2.4 CURRent Subsystem Commands

Used to set the measurement level current of the instrument.

Command Syntax:

:CURR?

:CURR <float | MIN | MAX>

Parameter:

float	Represents the floating-point data
MIN	Set the minimum possible value
MAX	Set the maximum possible value

Example:

:CURR 0.01	Set the measurement level to 10 mA
:CURR?	Return the level current

7.2.5 AMPLitude Subsystem Commands

Used to set the measurement speed and average times of the instrument.

Command Syntax:

```
:APER?
:APER <FAST+ | FAST | MED | SLOW> [,int]
```

Parameter:

FAST+	Fast+
FAST	Fast
MED	Medium
SLOW	Slow
int	Represent the value of the integer, ranging from 1 to 255

Example:

:APER FAST+	Set the measurement speed to fast+
:APER FAST	Set the measurement speed to fast
:APER MED	Set the measurement speed to medium
:APER SLOW	Set the measurement speed to slow
:APER FAST, 2	Set the measurement speed to fast, and average 2 times

7.2.6 OUTPut Subsystem Commands

7.2.6.1 Bias Source

Used to set the DC bias source of the instrument.

Command Syntax:

```
:OUTP:HPOW?
:OUTP:HPOW <INT | OPT | EXT>
```

Parameter:

INT	Internal 100 mA bias source
OPT	Internal 2 A bias source
EXT	External bias source

Example:

:OUTP:HPOW INT	Set the internal 100 mA bias source
:OUTP:HPOW OPT	Set the internal 2 A bias source
:OUTP:HPOW EXT	Set the external bias source
:OUTP:HPOW?	Return the bias source mode

7.2.6.2 DC Isolation

Used to set the DC isolation function switch of the instrument

Command Syntax:

```
:OUTP:DC:ISOL?
:OUTP:DC:ISOL <0 | 1 | OFF | ON>
```

Parameter:

0 OFF	OFF
1 ON	ON

Example:

:OUTP:DC:ISOL 0	Turn OFF DC isolation
:OUTP:DC:ISOL 1	Turn ON DC isolation
:OUTP:DC:ISOL?	Return the DC isolation function status

7.2.7 BIAS Subsystem Commands

The :BIAS subsystem commands are mainly used to set the internal bias voltage and the bias status.

7.2.7.1 Enable/Disable DC Bias**Command Syntax:**

```
:BIAS:STAT?
:BIAS:STAT <0 | 1 | OFF | ON>
```

Parameter:

0 OFF	OFF
1 ON	ON

Example:

:BIAS:STAT 0	Turn OFF the DC bias
:BIAS:STAT 1	Turn ON the DC bias
:BIAS:STAT?	Return the DC bias status

7.2.7.2 Bias Voltage

Used to set the internal bias voltage of the instrument.

Command Syntax:

```
:BIAS:VOLT?  
:BIAS:VOLT <float | MIN | MAX>
```

Parameter:

float	Represents the floating-point data
MIN	Set the minimum possible value
MAX	Set the maximum possible value

Example:

:BIAS:VOLT 1.2	Set the DC bias voltage to 1.2 V
:BIAS:VOLT?	Return the current DC bias voltage

7.2.7.3 Bias Current

Used to set the bias current of the instrument.

Command Syntax:

```
:BIAS:CURR?  
:BIAS:CURR <float | MIN | MAX>
```

Parameter:

float	Represents the floating-point data
MIN	Set the minimum possible value
MAX	Set the maximum possible value

Example:

:BIAS:CURR 0.01	Set the bias current to 10 mA
:BIAS:CURR?	Return the current bias current

7.2.7.4 Bias Polarity

Used to set the bias polarity of the instrument.

Command Syntax:

```
:BIAS:POL:AUTO?
```

```
:BIAS:POL:AUTO <0 | 1 | AUTO | FIX>
```

Parameter:

0 AUTO	AUTO
1 FIX	FIX

Example:

:BIAS:POL:AUTO 0	Set the bias polarity to AUTO
:BIAS:POL:AUTO 1	Set the bias polarity to FIX
:BIAS:POL:AUTO?	Return bias polarity status

7.2.8 TRIGger Subsystem Commands

7.2.8.1 Trigger Command

Command Syntax:

```
:TRIG
```

Example:

:TRIG	Trigger the instrument to measure once
-------	----------------------------------------

7.2.8.2 Trigger Mode

Used to set the trigger source mode of the instrument.

Command Syntax:

```
:TRIG:SOUR?
```

```
:TRIG:SOUR <CONT | SING>
```

Parameter:

CONT	Continuous
SING	Single

Example:

:TRIG:SOUR CONT	Set to continuous trigger
:TRIG:SOUR SING	Set to single trigger
:TRIG:SOUR?	Return the trigger mode

7.2.8.3 Trigger Delay

Used to set the trigger delay time of the instrument.

Command Syntax:

:TRIG:DEL?

:TRIG:DEL <float | MIN | MAX>

Parameter:

float	Represents the floating-point data
MIN	Set the minimum possible value
MAX	Set the maximum possible value

Example:

:TRIG:DEL 0	Set the trigger delay to 0
:TRIG:DEL 1ms	Set the trigger delay to 1 ms
:TRIG:DEL 1	Set the trigger delay to 1 s
:TRIG:DEL?	Return the trigger delay time

7.2.8.4 Trigger Status Query

Used to get the trigger status of the instrument.

Command Syntax:

:TRIGger:STATus?

Parameters:

RUN 0	...means idle or end of test
RUN 1	...means the test is running and has not yet finished

Example:

:TRIG:STAT? Returns RUN 0 or RUN 1 (return immediately)

Note: This instruction applies to the case where the test time is long and the host computer does not know the waiting time. It can constantly detect this state, and if, after the state becomes 0, you query the test results, you will receive the value of the test results immediately.

7.2.8.5 Trigger Reset

Equivalent to the panel reset button; used to set the pause or end of the instrument.

Command Syntax:

:TRIGger:ReSet

Example:

:TRIG:RST?

7.2.9 AMPLitude Auto Level Subsystem Commands

Used to turn on/off the automatic level control (ALC) function of the instrument.

Command Syntax:

```
:AMPL:ALC?
```

```
:AMPL:ALC <0 | 1 | OFF | ON>
```

Parameter:

0 | OFF OFF

1 | ON ON

Example:

```
:AMPL:ALC 0                      Turn OFF automatic level control
```

```
:AMPL:ALC 1                      Turn ON automatic level control
```

```
:AMPL:ALC?                      Return the automatic level control function status
```

7.2.10 Output RESister Internal Resistance Subsystem Commands

Used to set the output resistance mode of the instrument.

Command Syntax:

```
:ORES?
```

```
:ORES <100 | 30>
```

Parameter:

100 Set the output resistance of the instrument to 100 Ω

30 Set the output resistance of the instrument to 30 Ω

Example:

```
:ORES 100                      Set the output resistance of the instrument to 100  $\Omega$ 
```

```
:ORES 30                        Set the output resistance of the instrument to 30  $\Omega$ 
```

```
:ORES?                         Return the output internal resistance of the instrument
```

7.2.11 FUNCtion Subsystem Commands

7.2.11.1 Function Parameter

Used to configure the "function" parameters of the instrument.

Command Syntax:

```
:FUNC:IMP [1 | 2 | 3 | 4]?
```

```
:FUNC:IMP <para1, para2, para3, para4>
```

```
:FUNC:IMP <1 | 2 | 3 | 4> <para>
```

:FUNC:IMPSW <0 | 1>, <0 | 1>, <0 | 1>, <0 | 1>

:FUNC:IMPSW?

Parameter:

para₁, para₂, para₃, para₄ Indicates the optional function parameter name; the values are as follows:

Parameter Name	Parameter Meaning	Parameter Name	Parameter Meaning
CP	Equivalent Parallel Capacitance	CS	Equivalent Series Capacitance
LP	Equivalent Parallel Inductance	LS	Equivalent Series Inductance
RP	Equivalent Parallel Resistance	RS	Equivalent Series Resistance
GP	Conductance	BP	Susceptance
Z	Absolute Value of Impedance	Y	Absolute Value of Admittance
D	Loss Factor	Q	Quality Factor
ZTD/DZ	Θ_z° Impedance Degree	ZTR/RZ	Θ_z Impedance Radian
YTD/DY	Θ_y° Admittance Degree	YTR/RY	Θ_y Admittance Radian
X	Reactance	RD	DC Resistance

Example:

:FUNC:IMP CP, CS, LP, LS Set 4 parameter functions at the same time

:FUNC:IMP 1 RP Set parameter 1 to RP

:FUNC:IMP 2 RS Set parameter 1 to RS

:FUNC:IMP 3 Z Set parameter 1 to Z

:FUNC:IMP 4 Y Set parameter 1 to Y

:FUNC:IMP 1? Return the function of parameter 1

:FUNC:IMP 2? Return the function of parameter 2

:FUNC:IMP 3? Return the function of parameter 3

:FUNC:IMP 4? Return the function of parameter 4

:FUNC:IMP? Return the functions of all 4 parameters

:FUNC:IMPSW 1, 1, 0, 0 Turn parameters 1 and 2, turn off parameters 3 and 4

:FUNC:IMPSW 1, 0, 0, 0 Turn on parameter 1, turn off parameters 2, 3 and 4

:FUNC:IMPSW 1, 1, 1, 1 Turn on all 4 parameters

:FUNC:IMPSW? Return the on/off status of all 4 parameters (returns e.g. "1, 0, 0, 0")

7.2.11.2 AC Range

Used to set the AC range of the instrument.

Command Syntax:

:FUNC:IMP:RANG?

:FUNC:IMP:RANG <float>

Parameter:

float Indicates the floating point number, refer to the value of the equivalent resistance of the DUT.

Example:

:FUNC:IMP:RANG 1k Select the best range for 1 k Ω equivalent resistance
 :FUNC:IMP:RANG 1000 Select the best range for 1 k Ω equivalent resistance
 :FUNC:IMP:RANG 1200 Select the best range for 1.2 k Ω equivalent resistance
 :FUNC:IMP:RANG? Return the current AC range

7.2.11.3 AC Auto Range

Used to turn on/off the AC range auto mode of the instrument.

Command Syntax:

:FUNC:IMP:RANG:AUTO?
 :FUNC:IMP:RANG:AUTO <0 | 1 | OFF | ON>

Parameter:

0 | OFF (AUTO mode) OFF
 1 | ON (AUTO mode) ON

Example:

:FUNC:IMP:RANG:AUTO 0 Set the AC range mode to FIX
 :FUNC:IMP:RANG:AUTO 1 Set the AC range mode to AUTO
 :FUNC:IMP:RANG:AUTO? Return the AC range auto mode status

7.2.11.4 DC Range

Used to set the DC range of the instrument.

Command Syntax:

:FUNC:DCR:RANG?
 :FUNC:DCR:RANG <float>

Parameter:

float Indicates the floating point number, refer to the value of the equivalent resistance of the DUT.

Example:

:FUNC:DCR:RANG 1k Select the best range for 1 k Ω DCR
 :FUNC:DCR:RANG 1000 Select the best range for 1 k Ω DCR
 :FUNC:DCR:RANG 1200 Select the best range for 1.2 k Ω DCR
 :FUNC:DCR:RANG? Return the current DC range

7.2.11.5 VI Monitoring

Used to turn on/off the voltage monitoring of the instrument.

Command Syntax:

:FUNC:SMON:VAC?

:FUNC:SMON:VAC <0 | 1 | OFF | ON>

Parameter:

0 OFF	OFF
1 ON	ON

Example:

:FUNC:SMON:VAC 0	Turn OFF voltage monitoring
:FUNC:SMON:VAC 1	Turn ON voltage monitoring
:FUNC:SMON:VAC?	Return the voltage monitoring status

7.2.11.6 Current Monitoring

Used to turn on/off the current monitoring of the instrument.

Command Syntax:

:FUNC:SMON:IAC?

:FUNC:SMON:IAC <0 | 1 | OFF | ON>

Parameter:

0 OFF	OFF
1 ON	ON

Example:

:FUNC:SMON:IAC 0	Turn OFF current monitoring
:FUNC:SMON:IAC 1	Turn ON current monitoring
:FUNC:SMON:IAC?	Return the current monitoring switch status

7.2.11.7 Deviation and Reference

Used to set the deviation measurement mode of the instrument.

Command Syntax:

:FUNC:DEV [1 | 2 | 3 | 4] :MODE?

:FUNC:DEV [1 | 2 | 3 | 4] :MODE <ABS | PER | OFF>

Parameter:

ABS	Δ Absolute deviation
PER	$\Delta\%$ percent deviation
OFF	OFF

Example:

:FUNC:DEV 1:MODE ABS Set parameter 1 to absolute deviation
 :FUNC:DEV 2:MODE PER Set parameter 2 to percentage deviation
 :FUNC:DEV 3:MODE OFF Turn OFF the deviation mode of parameter 3
 :FUNC:DEV:MODE OFF, PER, ABS, OFF Set the deviation modes of all 4 parameters at the same time
 :FUNC:DEV 2:MODE? Return the deviation mode of parameter 2
 :FUNC:DEV:MODE? Return the deviation modes of all 4 parameters

7.2.11.8 Reference Value

Used to set the reference value of the deviation of the instrument.

Command Syntax:

:FUNC:DEV [1 | 2 | 3 | 4] :REF?
 :FUNC:DEV [1 | 2 | 3 | 4] :REF <float>
 :FUNC:DEV <1 | 2 | 3 | 4> :REF:FILL

Parameter:

float Represents the floating-point data

Example:

:FUNC:DEV 1:REF 10 Set the deviation reference of parameter 1 to 10
 :FUNC:DEV 2:REF:FILL Measure once; the result of parameter 2 is used as the deviation reference value
 :FUNC:DEV 4:REF? Return the deviation reference value of parameter 4
 :FUNC:DEV:REF? Return the deviation reference values of all 4 parameters
 :FUNC:DEV:REF 10, 11, 12, 13 Set the deviation reference values of all 4 parameters at the same time

7.2.11.9 Step Delay

Used to set the step delay time of the instrument.

Command Syntax:

:FUNC:SDEL?
 :FUNC:SDEL<float | MIN | MAX>

Parameter:

float Represents the floating-point data
 MIN Set the minimum possible value
 MAX Set the maximum possible value

Example:

:FUNC:SDEL 0 Set the step delay to 0
 :FUNC:SDEL 1ms Set the step delay to 1 ms

:FUNC:SDEL 1 Set the step delay to 1 s
:FUNC:SDEL? Return the step delay value;

7.2.12 COMPArator Subsystem Commands

7.2.12.1 Comparator Function

Used to turn on/off the comparator function of the instrument.

Command Syntax:

:COMP?
:COMP <0 | 1 | OFF | ON>

Parameter:

0 | OFF OFF
1 | ON ON

Example:

:COMP 0 Turn OFF the comparator function
:COMP 1 Turn ON the comparator function
:COMP? Return the comparator function status

7.2.12.2 Counting Function

Used to turn on/off the comparison counting function of the instrument.

Command Syntax:

:COMP:COUN?
:COMP:COUN <0 | 1 | OFF | ON>

Parameter:

0 | OFF OFF
1 | ON ON

Example:

:COMP:COUN 0 Turn OFF the comparison count function
:COMP:COUN 1 Turn ON the comparison count function
:COMP:COUN? Return the comparison count function status

7.2.12.3 Query the BIN Count Comparison Result

Command Syntax:

:COMP:COUN:DATA?

Example:

:COMP:COUN:DATA? Return the count result of each BIN

7.2.12.4 Clear All BIN Count Results**Command Syntax:**

:COMP:COUN:CLE

Example:

:COMP:COUN:CLE Clear all count results

7.2.12.5 Limit Mode

Used to set the instrument's comparison limit mode.

Command Syntax:

:COMP:MODE?

:COMP:MODE <TOL | SEQ>

Parameter:

TOL Tolerance mode

SEQ Sequential mode

Example:

:COMP:MODE TOL Set the comparison limit to tolerance mode

:COMP:MODE SEQ Set the comparison limit to sequential mode

:COMP:MODE? Return the comparison limit mode

7.2.12.6 Tolerance Mode Limit Values

Used to set the upper and lower limit values of each BIN in the tolerance mode of the comparison function (this function is accessible when the limit mode is set to tolerance mode).

Command Syntax:

:COMP:TOL:BIN <n>?

:COMP:TOL:BIN <n> <low_A, high_A> [...] [, low_D, high_D]

Parameter:

n BIN number index, the value is 1 ~ 10

low_A Represents the floating-point number of low limit of parameter 1

high_A Represents the floating-point number of high limit of parameter 1

low_D Represents the floating-point number of low limit of parameter 4

high_D Represents the floating-point number of high limit of parameter 4

Example:

:COMP:TOL:BIN 1 1, 2 Set the upper and lower limits of the first parameter of BIN 1 to [1,2]
 :COMP:TOL:BIN 3 1, 2, 3, 4 Set the upper and lower limits of the first two parameters of BIN 3 to [1,2],[3,4]
 :COMP:TOL:BIN 10 1, 2, 3, 4, 5, 6, 7, 8 Set the upper and lower limits of 4 parameters of 10 BINs
 :COMP:TOL:BIN 1? Return the upper and lower limits corresponding to the 4 parameters of BIN 1

7.2.12.7 Sequential Mode Limit Values

Used to set the upper and lower limit data of the sequential mode of the comparison function (this function is accessible when the limit mode is set to sequential mode).

Command Syntax:

:COMP:SEQ:BIN [A | B | C | D]?
 :COMP:SEQ:BIN [A | B | C | D] <lo₁> [, hi₁, hi₂,..., hi₁₀]

Parameter:

A | B | C | D Indicates the corresponding number of parameters in the 4 parameters
 lo₁ Represents the floating point data of the lower limit of BIN 1
 hi₁...hi₁₀ Represents the floating-point numbers of the upper limit of each BIN

Example:

:COMP:SEQ:BIN 1, 2, 3, 4, 5 Set the first parameter lo₁,hi₁,hi₂,hi₃,hi₄
 :COMP:SEQ:BIN A 1, 2, 3, 4, 5 Same as above
 :COMP:SEQ:BIN B 1, 2, 3, 4, 5, 6 Set the second parameter lo₁,hi₁,hi₂,hi₃,hi₄,hi₅
 :COMP:SEQ:BIN C 1, 2, 3, 4, 5, 6, 7, 8, 9, 10, 11 Set the upper and lower limits of the third parameter of each BIN
 :COMP:SEQ:BIN? Return the upper and lower limits of parameter 1, BIN 1 and the upper limits of other BINs
 :COMP:SEQ:BIN A? Same as above; default
 :COMP:SEQ:BIN B? Return the upper and lower limits of parameter 2, BIN 1, and the upper limits of other BINs
 :COMP:SEQ:BIN C? Return the upper and lower limits of parameter 3, BIN 1 and the upper limits of other BINs
 :COMP:SEQ:BIN D? Return the upper and lower limits of parameter 4, BIN 1 and the upper limits of other BINs

7.2.12.8 Clear Table

Used to clear the limit setting data of each BIN.

Command Syntax:

:COMP:BIN:CLE

Example:

:COMP:BIN:CLE Clear the limit data in the table

7.2.12.9 BIN Comparator Function

Used to turn on/off the comparator function of a specified BIN.

Command Syntax:

```
:COMP:BIN <n> :SW?
```

```
:COMP:BIN <n>:SW <0 | 1 | OFF | ON>
```

Parameter:

n	BIN number index, the value is 1 ~ 10
0 OFF	OFF
1 ON	ON

Example:

:COMP:BIN 1:SW 0	Turn OFF the comparator function of BIN 1
:COMP:BIN 2:SW 1	Turn ON the comparator function of BIN 2
:COMP:BIN 10:SW?	Return the BIN 10 comparator function status

7.2.13 LIST Subsystem Commands

7.2.13.1 Total Sweep Points

Used to set the total number of scan points in the list.

Command Syntax:

```
:LIST:TOTAL?
```

```
:LIST:TOTAL <int>
```

Parameter:

int	The total number of scan points; the value range is 1 ~ 201
-----	-------------------------------------------------------------

Example:

:LIST:TOTAL 8	Set the list sweep points to 8
:LIST:TOTAL 201	Set the list sweep points to 201
:LIST:TOTAL?	Return the number of sweep points in the list

7.2.13.2 List Sweep Mode

Used to set the list sweep mode of the instrument.

Command Syntax:

```
:LIST:MODE?
```

```
:LIST:MODE <SEQ | STEP>
```

Parameter:

SEQ	Sequential
STEP	Single-Step

Example:

:LIST:MODE SEQ	Set to sequential mode
:LIST:MODE STEP	Set to single-step mode
:LIST:MODE?	Return the list sweep mode

7.2.13.3 List Scan Comparator Function

Used to turn on/off the the list scan comparator function.

Command Syntax:

```
:LIST:COMP?
:LIST:COMP <0 | 1 | OFF | ON>
```

Parameters:

0 OFF	OFF
1 ON	ON

Example:

:LIST:COMP 0	Turn ON list scan comparator function
:LIST:COMP OFF	Turn OFF list scan comparator function
:LIST:COMP?	Return list scan comparator function current status

7.2.13.4 LISTDELTA Interpolation Mode

Used to turn on/off list scan parameter interpolation mode.

Command Syntax:

```
:LISTDELTA:SW?
:LISTDELTA:SW <0 | 1 | OFF | ON>
```

Parameter:

0 OFF	OFF
1 ON	ON

Example:

:LISTDELTA:SW 0	Turn ON list scan interpolation mode
:LISTDELTA:SW OFF	Turn OFF list scan interpolation mode
:LISTDELTA:SW?	Return the current status of the list scan interpolation mode

7.2.13.5 LISTDELTA Difference Mode

Used to set the difference mode of parameter 1 of each scan point when the list scan interpolation mode is on.

Command Syntax:

```
:LISTDELTA:MODE [n]?
```

```
:LISTDELTA:MODE [n] <mode>
```

Parameter:

<n> can take any value between 1 ~ 201 (total number of scanned points); <mode> can take any of the values 0, 1, 2, 3, 4, 5, 6, 7, 8, 9:

0	Mode $(P_n - P_1)$
1	Mode $(P_n - P_1) / P_1$
2	Mode $(P_n - P_1) / P_1 \times 100 \%$
3	Mode $(P_n - P_1) / P_n$
4	Mode $(P_n - P_1) / P_n \times 100 \%$
5	Mode (P_n)
6	Mode $(P_n - P_2) / P_2$
7	Mode $(P_n - P_2) / P_2 \times 100 \%$
8	Mode $(P_n - P_2) / P_n$
9	Mode $(P_n - P_2) / P_n \times 100 \%$

Example:

```
:LISTDELTA:MODE 2 0          Set the difference mode of scan point 2 to  $(P_n - P_1)$ , i.e.,  $P_2 - P_1$ 
```

```
:LISTDELTA:MODE 2?          Return the current interpolation mode of list scan point 2
```

7.2.13.6 LISTDELTA Lower Limit

Used to set the lower limit of the difference corresponding to the interpolation mode of the scan point when the list scan interpolation mode is on.

Command Syntax:

```
:LISTDELTA:LOW [n]?
```

```
:LISTDELTA:LOW [n] <value>
```

Parameter:

<n> can take any value between 3 ~ 201 (total number of scanned points); <value> takes the value type NR3.

Example:

```
:LISTDELTA:MODE 3 0          Set the difference mode of scan point 3 to  $(P_n - P_1)$  i.e.  $P_3 - P_1$ 
```

```
:LISTDELTA :LOW 3 -1          Based on the previous command, set the list scan interpolation mode on, and the difference mode of scan point 3 is  $(P_3 - P_1)$ , and the lower limit of this difference is -1, and its unit is the same as that of parameter 1
```

```
:LISTDELTA:LOW 3?          Return the lower limit of the current interpolation mode of list scan point 3
```

7.2.13.7 LISTDELTA Upper Limit

Used to set the upper limit of the difference that corresponds to the interpolation mode of the scan point when the list scan interpolation mode is on.

Command Syntax:

```
:LISTDELTA:HIGH [n]?
```

```
:LISTDELTA:HIGH [n] <value>
```

Parameter:

<n> can take any value between 1 ~ 201 (total number of sampled points); <value> takes the value type NR3.

Example:

```
:LISTDELTA:MODE 3 0          Set the difference mode of scan point 3 to ( $P_n - P_1$ ), i.e.  $P_3 - P_1$ 
```

```
:LISTDELTA:HIGH 3 10        Based on the previous command, the list scan interpolation mode is turned on, the difference mode of scan point 3 is ( $P_3 - P_1$ ), and the upper limit of this difference is 10. Its unit is the same as that of parameter 1
```

```
:LISTDELTA:HIGH 3?          Return the upper limit of the current interpolation mode of list scan point 3
```

7.2.13.8 List Scan Parameter Display

Used to turn on/off the list scan parameter display.

Command Syntax:

```
:LIST:DISP:PARA?
```

```
:LIST:DISP:PARA <0 | 1>, <0 | 1>, <0 | 1>, <0 | 1>, <0 | 1>, <0 | 1>
```

Parameter:

```
0 | OFF          Parameter display OFF; i.e. do not display, save or report the data
```

```
1 | ON          Parameter display ON
```

Example:

```
:LIST. DISP:PARA 1, 0, 0, 0    Configure the four parameters to turn ON the display for only the first one
```

```
:LIST:DISP:PARA 1, 1, 0, 0    Configure the four parameters to turn ON the display for only the first two
```

```
:LIST:DISP:PARA?              Return the display status of each of the four parameters
```

7.2.13.9 List Scan Frequency Display

Used to turn on/off the list scan frequency display.

Command Syntax:

```
:LIST. DISP:FREQ?
```

```
:LIST:DISP:FREQ <0 | 1 | OFF | ON>
```

Parameter:

0 OFF	OFF
1 ON	ON

Example:

:LIST:DISP:FREQ 1	Turn ON the frequency display
:LIST:DISP:FREQ 0	Turn OFF the frequency display
:LIST:DISP:FREQ?	Return the frequency display status

7.2.13.10 List Scan AC Level Display

Used to turn on/off the list scan AC level display.

Command Syntax:

```
:LIST:DISP:ACLV?
:LIST:DISP:ACLV <0 | 1 | OFF | ON>
```

Parameter:

0 OFF	OFF
1 ON	ON

Example:

:LIST:DISP:ACLV 1	Turn ON the AC level display
:LIST:DISP:ACLV 0	Turn OFF the AC level display
:LIST:DISP:ACLV?	Return the AC level display status

7.2.13.11 List Scan Bias Display

Used to turn on/off the list scan bias display.

Command Syntax:

```
:LIST:DISP:BIAS?
:LIST:DISP:BIAS <0 | 1 | OFF | ON>
```

Parameter:

0 OFF	OFF
1 ON	ON

Example:

:LIST:DISP:BIAS 1	Turn ON the bias display
:LIST:DISP:BIAS 0	Turn OFF the bias display
:LIST:DISP:BIAS?	Return the bias display status

7.2.13.12 Clear

Used to clear the setting data of all sweep points.

Command Syntax:

```
:LIST:CLE [n | ALL]
```

Parameter:

n	Specify the corresponding point of the list, the value is 1 ~ 201
ALL	Specify all points in the list

Example:

:LIST:CLE	Clear the setting data of all sweep points
:LIST:CLE ALL	Clear the setting data of all sweep points
:LIST:CLE 5	Clear the setting data of point 5

7.2.13.13 Sweep Point Frequency

Used to set the sweep point frequency / set the frequency of several points starting from the n^{th} point.

Command Syntax:

```
:LIST:FREQ [n]?
:LIST:FREQ [n] <fn> [, fn+1] [, fn+2]....
```

Parameter:

n	Start from the n^{th} point
f_n	Represents the floating-point number of sweep point n
f_{n+1}	Represents the floating-point number of sweep point n+1
...	

Example:

:LIST:FREQ 20, 30, 40	Set the frequency of the first 3 points
:LIST:FREQ 1 20, 30, 40, 1k, 2k	Set the frequency of the first 5 points
:LIST:FREQ 6 20, 30, 40, 1k, 2k	Set the frequency of 6 ~ 10 points
:LIST:FREQ 25 20k	Set the frequency of the 25th point
:LIST:FREQ?	Return the frequency of all sweep points
:LIST:FREQ 4?	Return the frequency of point 4

7.2.13.14 Sweep Point Voltage

Used to set the sweep point measurement level / set the voltage of several points starting from the n^{th} point.

Command Syntax:

```
:LIST:VOLT [n]?
:LIST:VOLT [n] <fn> [, fn+1] [, fn+2]....
```

Parameter:

n	Start from the n th point
f _n	Represents the floating-point number of sweep point n
f _{n+1}	Represents the floating-point number of sweep point n+1
...	

Example:

:LIST:VOLT 1, 2, 3, 4, 2	Set the voltage of the first 5 points
:LIST:VOLT 6 1, 2, 3, 4, 5	Set the voltage of 6 ~ 10 points
:LIST:VOLT 25 20	Set the voltage of the 25th point
:LIST:VOLT?	Return the voltage of all sweep points
:LIST:VOLT 4?	Return the voltage of point 4

7.2.13.15 Sweep Point Current

Used to set the sweep point current / set the current value of several points starting from the nth point.

Command Syntax:

```
:LIST:CURRE [n]?
:LIST:CURRE [n] <fn> [, fn+1] [, fn+2]...
```

Parameter:

n	Start from the n th point
f _n	Represents the floating-point number of sweep point n
f _{n+1}	Represents the floating-point number of sweep point n+1
...	

Example:

:LIST:CURRE 1m, 2m, 3m, 4m, 2m	Set the current of the first 5 points
:LIST:CURRE 6 1m, 2m, 3m, 4m, 5m	Set the current of 6 ~ 10 points
:LIST:CURRE 25 20m	Set the current of the 25 th point
:LIST:CURRE?	Return the current of all sweep points
:LIST:CURRE 4?	Return the current of point 4

7.2.13.16 Bias Voltage

Used to set the sweep point bias voltage / set the bias voltage of several points starting from the nth point

Command Syntax:

```
:LIST:BIAS:VOLT [n]?
:LIST:BIAS:VOLT [n] <fn> [, fn+1] [, fn+2]...
```

Parameter:

n	Start from the n th point
f _n	Represents the floating-point number of sweep point n
f _{n+1}	Represents the floating-point number of sweep point n+1
...	

Example:

:LIST:BIAS:VOLT 1, 2, 3	Set the bias voltage of the first 3 points
:LIST:BIAS:VOLT 6 1, 2, 3, 4, 5	Set the bias voltage of 6 ~ 10 points
:LIST:BIAS:VOLT?	Return the bias voltage of all sweep points
:LIST:BIAS:VOLT 4?	Return the bias voltage of point 4

7.2.13.17 Bias Current

Used to set the sweep point bias current / set the bias current of several points starting from the nth point.

Command Syntax:

```
:LIST:BIAS:CURR [n]?
:LIST:BIAS:CURR [n] <fn> [, fn+1] [, fn+2]....
```

Parameter:

n	Start from the n th point
f _n	Represents the floating-point number of sweep point n
f _{n+1}	Represents the floating-point number of sweep point n+1
...	

Example:

:LIST:BIAS:CURR 1m, 2m, 3m	Set the bias current of the first 3 points
:LIST:BIAS:CURR 6 1m, 2m, 3m, 4m, 5m	Set the bias current of points 6 ~ 10
:LIST:BIAS:CURR?	Return the bias current of all points
:LIST:BIAS:CURR 4?	Return the bias current of point 4

7.2.13.18 List Sweep Function Parameters

Used to set the function parameters of the specified point of the list sweep.

Command Syntax:

```
:LIST:FUNC:IMP <n>?
:LIST:FUNC:IMP <n> <para1, para2, para3, para4>
```

Parameter:

n	Specifies the index of the sweep point, ranging from 1 to 201
para1, para2, para3, para4	Indicates the optional function parameter name, the values are as follows:

Parameter Name	Parameter Meaning	Parameter Name	Parameter Meaning
CP	Equivalent Parallel Capacitance	CS	Equivalent Series Capacitance
LP	Equivalent Parallel Inductance	LS	Equivalent Series Inductance
RP	Equivalent Parallel Resistance	RS	Equivalent Series Resistance
GP	Conductance	BP	Susceptance
Z	Absolute Value of Impedance	Y	Absolute Value of Admittance
D	Loss Factor	Q	Quality Factor
ZTD/DZ	Θ_z° Impedance Degree	ZTR/RZ	Θ_z Impedance Radian
YTD/DY	Θ_y° Admittance Degree	YTR/RY	Θ_y Admittance Radian
X	Reactance	RD	DC Resistance

Example:

```
:LIST:FUNC:IMP 1 CP, CS, LP, LS   Set the 4 parameter functions of point 1
:LIST:FUNC:IMP 5 CP, CS, LP, LS   Set the 4 parameter functions of point 5
:LIST:FUNC:IMP 100 CP, CS, LP, LS Set the 4 parameter functions of the 100th point
:LIST:FUNC:IMP 1?                  Return the 4-parameter functions of point 1
```

7.2.13.19 Specified Parameters

Used to set the function of list sweep specified parameters / set the function of several points starting from the n^{th} point.

Command Syntax:

```
:LIST:FUNC:IMP <A | B | C | D> <n>?
:LIST:FUNC:IMP <A | B | C | D> <n> <pn> [, pn+1, pn+2,...]
```

Parameter:

A | B | C | D Indicate that one of the 4 parameters is specified

n Specify the index of the sweep point, ranging from 1 to 201

p_n The function name of sweep point n, (refer to the table above)

p_{n+1} The function name of sweep point n+1

...

Example:

```
:LIST:FUNC:IMP A CP, CS, LP   Set the parameter function of points 1 ~ 3 of the first parameter
:LIST:FUNC:IMP B 5 CP, CS     Set the parameter function of points 5 ~ 6 of the second parameter
:LIST:FUNC:IMP C?            Return all points' parameter functions of the third parameter
:LIST:FUNC:IMP D 11?        Return the parameter function of point 11 of the fourth parameter
```

7.2.13.20 Linear Setting of the Specified Parameter

Command Syntax:

```
:LIST:FUNC:LIN <A | B | C | D> <start, stop, para>
```

Parameter:

A B C D	Indicate that one of the 4 parameters is specified
start	Specify the starting point of the setting, the value is 1 ~ 201
stop	Specify the end point of the setting, the value is 1 ~ 201
para	Function name (refer to the table above)

Example:

:LIST:FUNC:LIN A 1, 15, LP	Set the function of point 1 ~ 15 of the first parameter to LP
:LIST:FUNC:LIN B 5, 201, CP	Set the function of point 5 ~ 201 of the second parameter to CP
:LIST:FUNC:LIN D 3, 15, LP	Set the function of point 3 ~ 15 of the fourth parameter to LP

7.2.13.21 BAND Limit

Used to set the limit data at the specified point in the list sweep setting table.

Command Syntax:

```
:LIST:BAND <n>?
:LIST:BAND <n> OFF
:LIST:BAND <n> <A | B | C | D> <lo, hi>
```

Parameter:

n	Specify the index of the sweep point, ranging from 1 to 201
A B C D	Indicate that one of the 4 parameters is specified
lo	The lower limit of the parameter corresponding to the specified point
hi	The upper limit of the parameter corresponding to the specified point

Example:

:LIST:BAND 1 OFF	Clear the limit data of all 4 parameters at point 1
:LIST:BAND 2 A, 1, 2	Set the lower limit value at point 2 of the 2 nd parameter to 1 and the upper limit value to 2
:LIST:BAND 201 D, 1.1, 2.2	Set the lower limit value at point 201 of the 4 th parameter to 1.1 and the upper limit value to 2.2
:LIST:BAND 9?	Return the upper and lower limits of all 4 parameters at point 9, lo _A , hi _A , lo _B , hi _B ...

7.2.13.22 Measurement Delay

Used to set the measurement delay of the sweep point / set the delay time of several points starting from the n^{th} point.

Command Syntax:

:LIST:DEL [n]?

:LIST:DEL [n] < f_n > [, f_{n+1}] [, f_{n+2}]...

Parameter:

n	Start from the n^{th} point
f_n	Represents the floating point number of the sweep point n
f_{n+1}	Represents the floating point number of the sweep point n+1
...	

Example:

:LIST:DEL 0.01, 20m, 30m	Set the measurement delay of the first 3 points
:LIST:DEL 1m, 2m, 3m, 4m, 2m	Set the measurement delay of the first 5 points
:LIST:DEL 6 1m, 2m, 3m, 4m, 5m	Set the measurement delay of points 6 ~ 10
:LIST:DEL 25 20m	Set the measurement delay of the 25 th point
:LIST:DEL?	Return the measurement delay of all sweep points
:LIST:DEL 4?	Return the measurement delay of point 4

7.2.14 TRACE Subsystem Commands

7.2.14.1 Sweep Points

Used to set the number of LCR curve scan points.

Command Syntax:

:TSSE:POINT?

:TSSE:POINT <51 | 101 | 201 | 401 | 801>

Parameter:

51	...means scanning 51 points
101	...means scanning 101 points
201	...means scanning 201 points
401	...means scanning 401 points
801	...means scanning 801 points

Example:

:TSSE:POINT 51	Set LCR to scan 51 points
:TSSE:POINT 101	Set LCR to scan 101 points
:TSSE:POINT 201	Set LCR to scan 201 points

:TSSE:POINT 401	Set LCR to scan 401 points
:TSSE:POINT 801	Set LCR to scan 801 points
:TSSE:POINT?	Return the LCR sweep points

7.2.14.2 Sweep Parameter Mode

Used to set the sweep parameter mode of the LCR curve.

Command Syntax:

```
:TSSE:MODE?
:TSSE:MODE <FREQ | VOLT | CURR | BVOL | BCUR>
```

Parameter: string parameter, select from list

Example:

:TSSE:MODE FREQ	Set the LCR sweep parameter to frequency
:TSSE:MODE VOLT	Set the LCR sweep parameter to voltage
:TSSE:MODE CURR	Set the LCR sweep parameter to current
:TSSE:MODE BVOL	Set LCR sweep parameter as bias voltage
:TSSE:MODE BCUR	Set LCR sweep parameter as bias current
:TSSE:MODE?	Return the LCR sweep parameter type

7.2.14.3 Sweep Range

Used to set the LCR sweep range (start and stop points).

Command Syntax:

```
:TSSE:SWEEP?
:TSSE:SWEEP <float, float>
```

Parameter:

float Represents floating-point string format data, e.g. "3.14159"

Example:

:TSSE:SWEEP 1, 100	Set the LCR sweep start and stop point
:TSSE:SWEEP?	Return the LCR sweep start and stop point

7.2.14.4 Sweep Mode

Used to set the LCR sweep mode.

Command Syntax:

```
:TSSE:SMODE?
:TSSE:SMODE <SEQ | STEP>
```

Parameter:

SEQ	Sequential
STEP	Single-Step

Example:

:TSSE:SMODE SEQ	Set the LCR sweep mode to sequential mode
:TSSE:SMODE STEP	Set the LCR sweep mode to single-step mode
:TSSE:SWEEP?	Return the LCR sweep mode

7.2.14.5 Format Mode

Used to set the LCR curve format mode.

Command Syntax:

```
:TSSE:FORM?
:TSSE:FORM <LIN | LOGX>
```

Parameter:

LIN	Linear coordinates
LOGX	X-axis logarithm

Example:

:TSSE:FORM LIN	Set the LCR sweep coordinate as linear coordinates
:TSSE:FORM LOGX	Set the LCR sweep coordinate as the X axis logarithm
:TSSE:FORM?	Return the LCR sweep coordinate mode

7.2.14.6 Limit Function

Used to turn on/off the LCR curve limit function.

Command Syntax:

```
:TSSE:LIMI?
:TSSE:LIMI <0 | 1 | OFF | ON>
```

Parameter:

0 OFF	OFF
1 ON	ON

Example:

:TSSE:LIMI 0	Turn OFF the LCR sweep limit
:TSSE:LIMI 1	Turn ON the LCR sweep limit
:TSSE:LIMI?	Return the LCR sweep limit status

7.2.14.7 LCR Sweep Function Parameters

Used to set the LCR sweep function parameters.

Command Syntax:

```
:TSSE:IMP [1 | 2 | 3 | 4]?
```

```
:TSSE:IMP <para1, para2, para3, para4>
```

```
:TSSE:IMP <1 | 2 | 3 | 4> <para>
```

Parameter:

para1, para2, para3, para4 Indicates the optional function parameter name, the values are as follows:

Parameter Name	Parameter Meaning	Parameter Name	Parameter Meaning
CP	Equivalent Parallel Capacitance	CS	Equivalent Series Capacitance
LP	Equivalent Parallel Inductance	LS	Equivalent Series Inductance
RP	Equivalent Parallel Resistance	RS	Equivalent Series Resistance
GP	Conductance	BP	Susceptance
Z	Absolute Value of Impedance	Y	Absolute Value of Admittance
D	Loss Factor	Q	Quality Factor
ZTD/DZ	Θ_z° Impedance Degree	ZTR/RZ	Θ_z Impedance Radian
YTD/DY	Θ_y° Admittance Degree	YTR/RY	Θ_y Admittance Radian
X	Reactance	RD	DC Resistance

Example:

```
:TSSE:IMP CP, CS, LP, LS                      Set all 4 parameter functions at the same time
:TSSE:IMP 1 RP                                  Set parameter 1 to RP
:TSSE:IMP 2 RS                                  Set parameter 1 to RS
:TSSE:IMP 3 Z                                   Set parameter 1 to Z
:TSSE:IMP 4 Y                                   Set parameter 1 to Y
:TSSE:IMP 1?                                   Return parameter 1 function
:TSSE:IMP 2?                                   Return parameter 2 function
:TSSE:IMP 3?                                   Return parameter 3 function
:TSSE:IMP 4?                                   Return parameter 4 function
:TSSE:IMP?                                       Return the functions of all 4 parameters
```

7.2.14.8 Auto-Scaling

Used to configure the LCR auto-scaling function.

Command Syntax:

```
:TSSE:SCAL?
```

```
:TSSE:SCAL <AUTO | HOLD>
```

Parameter:

AUTO	AUTO mode
HOLD	HOLD mode

Example:

:TSSE:SCAL AUTO	Set LCR auto-scaling to auto
:TSSE:SCAL HOLD	Set LCR auto-scaling to hold
:TSSE:SCAL?	Return LCR scanning auto-scaling status

7.2.14.9 ABCD Vertical Coordinate Range

Used to set the highest value of LCR curve coordinates.

Command Syntax:

```
:TSSE:<A | B | C | D>?
:TSSE:<A | B | C | D> <min, max>
```

Parameter:

A B C D	Indicate that one of the 4 parameters is specified
min	Lower limit value of coordinate range
max	Upper limit value of coordinate range

Example:

:TSSE:A 10, 1000	Set LCR scan parameter A vertical coordinate range to 10 ~ 1000
:TSSE:B 10, 1000	Set LCR scan parameter B vertical coordinate range to 10 ~ 1000
:TSSE:C 10, 1000	Set LCR scan parameter C vertical coordinate range to 10 ~ 1000
:TSSE:D 10, 1000	Set LCR scan parameter D vertical coordinate range to 10 ~ 1000
TSSE:A?	Return LCR scan parameter A coordinate range
TSSE:B?	Return LCR scan parameter B coordinate range
TSSE:C?	Return LCR scan parameter C coordinate range
TSSE:D?	Return LCR scan parameter D coordinate range

7.2.14.10 Split Screen

Used to configure the LCR curve split screen setting.

Command Syntax:

```
:TSSE:SPLI?
:TSSE:SPLI <1 | 2 | 4>
```

Parameter:

1	No split screen / one screen
2	Split screen in two
4	Split screen in four

Example:

:TSSE:SPLI 1 Set LCR scan split screen function to one screen
 :TSSE:SPLI 2 Set LCR scan split screen function to a two-way split
 :TSSE:SPLI 4 Set LCR scan split screen function to a four-way split
 :TSSE:SPLI? Return LCR scan split screen function status

7.2.14.11 Curve Display

Turn on/off LCR curve display; supports configuring up to 4 curve displays at the same time.

Command Syntax:

:TSSE:SW?
 :TSSE:SW [1 | 2 | 3 | 4] <0 | 1 | 2> [, 0 | 1 | 2]...

Parameter:

SW [1 | 2 | 3 | 4] ...specifies which curve to start from (omitting this number automatically sets it to start at the first curve)
 0 OFF
 1 ON
 2 Maintain; omits the specified curve after running through SW

Example:

:TSSE:SW 0, 0, 0, 0 Set LCR scan to not display any of the 4 curves
 :TSSE:SW 0, 1, 0, 1 Set LCR scan to turn on only the 2nd and 4th curves
 :TSSE:SW 2, 1, 2, 1 Set LCR scan to disable 1st and 3rd curve displays
 :TSSE:SW 4 0 Set LCR scan to turn off the 4th curve display
 :TSSE:SW? Return LCR scan curve display status

7.2.15 Handler Subsystem Commands**7.2.15.1 Handler Mode**

Used to set the LCR handler mode.

Command Syntax:

:HAND:STAT?
 :HAND:STAT <0 | 1 | 2 | OFF | ON | BUS>

Parameter:

0 | OFF Default
 1 | ON Custom
 2 | BUS BUS Control

Example:

:HAND:STAT 0	Set the handler mode to default
:HAND:STAT OFF	Set the handler mode to default
:HAND:STAT 1	Set the handler mode to custom
:HAND:STAT ON	Set the handler mode to custom
:HAND:STAT BUS	Set the handler mode to BUS

7.2.15.2 Custom Output

Used to control the LCR Handler custom output.

Command Syntax:

```
:HAND:STAT:OFLO <...>
:HAND:STAT:OFHI <...>
:HAND:STAT:LVLO <...>
:HAND:STAT:LVHI <...>
:HAND:STAT:PUHI <...>
:HAND:STAT:PULO <...>
```

Parameter:

<...> is a list format, e.g. 1, 2, 4, 7, 14, 24, etc., corresponding to the table position displayed by the instrument.

Example:

:HAND:STAT:OFLO 1, 3, 5, 9	Set the index function of 1, 3, 5, 9 to a constant low level
:HAND:STAT:OFHI 1, 3, 5, 9	Set the index function of 1, 3, 5, 9 to a constant high level
:HAND:STAT:LVLO 1, 3, 5, 9	Set the index function of 1, 3, 5, 9 to an active low level
:HAND:STAT:LVHI 1, 3, 5, 9	Set the index function of 1, 3, 5, 9 to an active high level
:HAND:STAT:PUHI 1, 3, 5, 9	Set the index function of 1, 3, 5, 9 to an active high pulse
:HAND:STAT:PULO 1, 3, 5, 9	Set the index function of 1, 3, 5, 9 to an active low pulse

7.2.15.3 Bus Output

Used to control the LCR Handler bus output.

Command Syntax:

```
:HAND:OUTP:LVHI <...>
:HAND:OUTP:LVLO <...>
```

Parameter:

<...> is a list format, e.g. 1, 2, 4, 7, 14, 24, etc., corresponding to the table position displayed by the instrument.

Example:

:HAND:LVHI:LVHI 1, 3, 5, 9	Set 1, 3, 5, 9 to high level output in bus mode
:HAND:LVLO:LVLO 1, 3, 5, 9	Set 1, 3, 5, 9 to low level output in bus mode

7.2.16.3 Automatic Return of Data

Used to configure the AUTO FETCh setting (this state is not saved after power-off).

Command Syntax:

```
:FETC:AUTO?
```

```
:FETC:AUTO <0 | 1 | 2 | 3 | OFF | ON>
```

Parameter:

0 OFF	OFF
1 ON	ON (.i.e. trigger the end of the test to automatically return to the test results of this measurement; the result format is the same as the above FETC?)
2	Trigger the end of the test results to return to the end of the status, do not directly return the results; <ul style="list-style-type: none"> return "Trig Eom\n" indicates the end of the test return "Trig Pause\n" indicates that the test is paused.

Example:

:FETC:AUTO 0	Turn OFF the AUTO FETCh function
:FETC:AUTO 1	Turn ON the AUTO FETCh function (automatically return measurement results after end of test)
:FETC:AUTO 2	Set the AUTO FETCh function to return to end state after end of test; do not return test results
:FETC:AUTO?	Return the AUTO FETCh function's status

7.2.16.4 List Sweep Results

Used to fetch the list sweep results.

Command Syntax:

```
:FETC:LIST:PARA <1 | 2 | 3 | 4>?
```

```
:FETC:LIST:PT <1 ~ 201>?
```

```
:FETC:LIST:COMP [1 ~ 201]?
```

```
:FETC:LIST [1 ~ 201]?
```

Parameter:

PARA <1 2 3 4>	Measurement result of the specified parameter in list sweep
PT <1 ~ 201>	Measurement results of all parameters at the specified point
COMP [1 ~ 201]	Comparison results at the specified point in the list
LIST [1 ~ 201]	Results of all parameters at all points within this list

Example:

:FETC:LIST:PARA 1?	Return the measurement result of list sweep parameter 1
:FETC:LIST:PARA 3?	Return the measurement result of the list sweep parameter 3

:FETC:LIST:PT 5?	Return the result of all parameters at point 5
:FETC:LIST:COMP?	Return the comparison results at all points in the list
:FETC:LIST:COMP 4?	Return the comparison result of the 4 th item in the list
:FETC:LIST?	Returns the measurement results of all 4 parameters at all points in the list e.g. P1.1, P1.2, P1.3, P1.4, P1.cmp, P2.1...
:FETC:LIST 3?	Return the list at point 3 of the 4 parameters and the results of the comparison

Note: Separate multiple pieces of data using the comma. If there is a parameter display that is turned off, then the separator in the middle of the data content is no data.

7.2.16.5 Trace Sweep Results

Used to fetch the trace sweep results.

Command Syntax:

```
:FETC:TRACE:X [1 ~ 801]?
:FETC:TRACE:Y <1 | 2 | 3 | 4>?
:FETC:TRACE:PT <1 ~ 801>?
:FETC:TRACE:MARK?
:FETC:TRACE:YMAX <1 | 2 | 3 | 4>?
:FETC:TRACE:YMIN <1 | 2 | 3 | 4>?
```

Parameter:

X [1 ~ 801]	The abscissa of the trace sweep
Y <1 2 3 4>	The measurement result of the specified curve (all points)
PT <1 ~ 801>	The measurement result at the specified point (x, y ₁ , y ₂ , y ₃ , y ₄)
MARK	The measurement results at the cursor of all traces (x, y ₁ , y ₂ , y ₃ , y ₄)
YMAX <1 2 3 4>	The maximum value (x, y) of the specified curve
YMIN <1 2 3 4>	The minimum value (x, y) of the specified curve

Example:

:FETC:TRACE:X?	Return a list of all the abscissa data of the trace sweep
:FETC:TRACE:X 5?	Return the abscissa of point 5 of the trace sweep
:FETC:TRACE:Y 2?	Return the measurement result of trace curve 2
:FETC:TRACE:PT 5?	Return the result of all curves at point 5
:FETC:TRACE:MARK?	Return the result at the curve cursor (x, y ₁ , y ₂ , y ₃ , y ₄)
:FETC:TRACE:YMAX 1?	Return the maximum value of curve 1 (x, y)
:FETC:TRACE:YMIN 3?	Return the minimum value of curve 3 (x, y)

7.2.17 CORRection Subsystem Commands

7.2.17.1 Execute Open-Circuit Correction

Used to execute preset measurement point open-circuit correction.

Command Syntax:

:CORR:OPEN [ACK]

Example:

:CORR:OPEN Perform the open-circuit correction on the preset point, no return

:CORR:OPEN ACK Perform the open-circuit correction on the preset point

Return 1 for success and 0 for failure.

7.2.17.2 Open-Circuit Correction Function

Used to turn on/off the open-circuit correction function.

Command Syntax:

:CORR:OPEN:STAT?

:CORR:OPEN:STAT <0 | 1 | OFF | ON>

Parameter:

0 | OFF OFF

1 | ON ON

Example:

:CORR:OPEN:STAT 0 Turn OFF the open-circuit correction function

:CORR:OPEN:STAT 1 Turn ON the open-circuit correction function

:CORR:OPEN:STAT? Return the open-circuit correction function status

7.2.17.3 Execute Short-Circuit Correction

Used to execute preset measurement point short-circuit correction.

Command Syntax:

:CORR:SHOR [ACK]

Example:

:CORR:SHOR Perform short-circuit correction on preset point, no return

:CORR:SHOR ACK Perform short-circuit correction on preset point

Return 1 for success and 0 for failure.

Parameter Name	Parameter Meaning
LSRS	LS-RS
LSQ	LS-Q
CPD	CP-D

Example:

:CORR:LOAD:TYPE LSRS Set the load type to LS-RS
 :CORR:LOAD:TYPE LSQ Set the load type to LS-Q
 :CORR:LOAD:TYPE CPD Set the load type to CP-D
 :CORR:LOAD:TYPE? Return the load type

7.2.17.7 Cable Length

Used to set the correction cable length of the instrument.

Command Syntax:

:CORR:LENG?
 :CORR:LENG <0 | 1>

Parameter:

0 0 m
 1 1 m

Example:

:CORR:LENG 0 Set the cable length to 0 meter
 :CORR:LENG 1 Set the cable length to 1 meter
 :CORR:LENG? Return the cable length

7.2.17.8 Clear User Correction Data**Command Syntax:**

:CORR:CLE [pt]

Parameter:

[pt] indicating the specified correction point index; value range of 1 ~ 10

Example:

:CORR:CLE Clear all user correction data
 :CORR:CLE 1 Clear the correction data of point 1 calibrated by the user
 :CORR:CLE 4 Clear the correction data of point 4 calibrated by the user
 :CORR:CLE 10 Clear the correction data of point 10 calibrated by the user

7.2.17.9 Query the User Correction Data

Command Syntax:

:CORR[:USE]:DATA [n]?

Parameter:

n The value is 1 ~ 10, which indicates the index of nth of dot frequency clearing point

Example:

:CORR:DATA? Return the open-circuit correction value, short-circuit correction value, load correction value of all set points:

<open₁ A>, <open₁ B>, <short₁ A>, <short₁ B>, <load₁ A>, <load₁ B>, <open₂ A>, <open₂ B>, <short₂ A>, <short₂ B>, <load₂ A>, <load₂ B>...

:CORR:DATA 1? Return the correction data of point 1:

<point index (1)>, <frequency>, <open A>, <open B>, <short A>, <short B>, <load A>, <load B>, <reference A>, <reference B>

:CORR:DATA 2? Return the correction data of point 2

<point index (2)>, <frequency>, <open A>, <open B>, <short A>, <short B>, <load A>, <load B>, <reference A>, <reference B>

:CORR:DATA 3? Return the correction data of point 3:

<point index (3)>, <frequency>, <open A>, <open B>, <short A>, <short B>, <load A>, <load B>, <reference A>, <reference B>

:CORR:DATA 10? Return the correction data of point 10:

<point index (10)>, <frequency>, <open A>, <open B>, <short A>, <short B>, <load A>, <load B>, <reference A>, <reference B>

7.2.17.10 Query the User Correction Time

Command Syntax:

:CORR:DATE <LAST | OPEN | SHORT | DCR | DCROPEN | DCRSHORT>

:CORR:DATE <n> <OPEN | SHORT | LOAD>

Parameter:

DATE <n> n indicates the nth frequency point

LAST Indicates the time of the last clearing operation

OPEN | SHORT | LOAD Represents open-circuit correction, short-circuit correction, and load correction, respectively

DCR | DCROPEN | DCRSHORT Represents DCR, DCR open-circuit correction, and DCR short-circuit correction, respectively

Example:

:CORR:DATE LAST Return the time of the last correction

:CORR:DATE OPEN Return the time of the full frequency open-circuit correction

:CORR:DATE SHORT	Return the time of the full-frequency short-circuit correction
:CORR:DATE DCR	Return the time of the last DCR correction
:CORR:DATE DCROPEN	Return the time of the DCR open-circuit correction
:CORR:DATE DCRSHORT	Return the time of the DCR short-circuit correction
:CORR:DATE 1 LAST	Return the time of the last correction at frequency point 1
:CORR:DATE 2 OPEN	Return the time of the open-circuit correction at frequency point 2
:CORR:DATE 3 SHORT	Return the time of the short-circuit correction at frequency point 3
:CORR:DATE 10 LOAD	Return the time of the load correction at frequency point 10

Note: The format of the returned data is "yyyy-MM-dd hh:mm:ss", and a return of "----" indicates that the date is invalid; that is, the correction has not been performed.

7.2.17.11 Specified Frequency Point

Used to turn on/off the the specified frequency point.

Command Syntax:

```
:CORR:SPOT <n>:STAT?
```

```
:CORR:SPOT <n>:STAT <0 | 1 | OFF | ON>
```

Parameter:

n	Frequency point index, value 1 ~ 10
0 OFF	OFF
1 ON	ON

Example:

:CORR:SPOT 1:STAT 0	Turn OFF frequency point 1
:CORR:SPOT 3:STAT 1	Turn ON frequency point 3
:CORR:SPOT 10:STAT?	Return the status of frequency point 10

7.2.17.12 Measurement Frequency

Used to specify the measurement frequency of the frequency point.

Command Syntax:

```
:CORR:SPOT <n>:FREQ?
```

```
:CORR:SPOT <n>:FREQ <float | MIN | MAX>
```

Parameter:

float	Represents the floating-point data
MIN	Set the minimum possible value
MAX	Set the maximum possible value

Example:

:CORR:SPOT 1:FREQ 1200	Set the frequency to 1200 Hz
:CORR:SPOT 2:FREQ 1100Hz	Set the frequency to 1100 Hz
:CORR:SPOT 3:FREQ 1.2k	Set the frequency to 1200 Hz
:CORR:SPOT 4:FREQ?	Return the frequency of frequency point 4

7.2.17.13 Open-Circuit Correction at Specific Frequency

Used to execute an open-circuit correction at specific frequency points (frequency 1, frequency 2, etc.).

Command Syntax:

```
:CORR:SPOT <n>:OPEN
```

Example:

:CORR:SPOT 1:OPEN	Perform open-circuit correction at frequency point 1
:CORR:SPOT 2:OPEN	Perform open-circuit correction at frequency point 2
:CORR:SPOT 10:OPEN	Perform open-circuit correction at frequency point 10

Return 1 for success and 0 for failure.

7.2.17.14 Short-Circuit Correction at Specific Frequency

Used to execute a short-circuit correction at specific frequency points (frequency 1, frequency 2, etc.).

Command Syntax:

```
:CORR:SPOT <n>:SHOR
```

Example:

:CORR:SPOT 1:SHOR	Perform short-circuit correction at frequency point 1
:CORR:SPOT 2:SHOR	Perform short-circuit correction at frequency point 2
:CORR:SPOT 10:SHOR	Perform short-circuit correction at frequency point 10

Return 1 for success and 0 for failure.

7.2.17.15 Reference Values for Load Correction at Specific Frequency

Used to set the load correction reference values for specific frequency points (frequency 1, frequency 2, etc.).

Command Syntax:

```
:CORR:SPOT <n>:LOAD:STAN?
:CORR:SPOT <n>:LOAD:STAN <refA, refB>
```

Parameter:

ref _A	Represents the floating point data of reference A
ref _B	Represents the floating point data of reference B

Example:

:CORR:SPOT 1:LOAD:STAN 1.1, 1.2 The reference value for load correction at frequency point 1
 :CORR:SPOT 2:LOAD:STAN 1.1, 1.2 The reference value for load correction at frequency point 2
 :CORR:SPOT 10:LOAD:STAN? Return the reference value for load correction of frequency point 10

7.2.17.16 Load Correction at Specific Frequency

Used to execute a load correction at specific frequency points (frequency 1, frequency 2, etc.).

Command Syntax:

:CORR:SPOT <n>:LOAD

Example:

:CORR:SPOT 1:LOAD Perform load correction at frequency point 1
 :CORR:SPOT 2:LOAD Perform load correction at frequency point 2
 :CORR:SPOT 10:LOAD Perform load correction at frequency point 10

Return 1 for success and 0 for failure.

7.2.18 Mass MEMory Subsystem Commands

The Mass MEMory subsystem commands are used to save and load files.

7.2.18.1 Load

Used to load saved files.

Command Syntax:

:MMEM:LOAD?
 :MMEM:LOAD <file>

Parameter:

file Specifies the path of the file to be loaded, relatively complete file path or the index number of the internal file fixed file, ranging from 1 to 50

The corresponding relationship between the index number and the file is as follows:

Index Number	LCR Mode
1 ~ 50	LCR.sda/LCR2.sda... in the root directory of internal files

Example:

:MMEM:LOAD 1 Load the file with the path LCR.sta
 :MMEM:LOAD 9 Load the file with the path LCR9.sta
 :MMEM:LOAD sss.sta Load the file with the path files/sss.sta

:MMEM:LOAD files/sss.sta	Load the file with the path files/sss.sta
:MMEM:LOAD usb/sss.sta	Load the file with the path usb/sss.sta
:MMEM:LOAD?	Return the path name of the file to load

7.2.18.2 Store

Used to save the current instrument settings to a file.

Command Syntax:

```
:MMEM:STOR <n> [, file]
```

Parameter:

n	For use with the default saved file naming
file	Specifies the name of the file to save

The corresponding relationship between the index number and the default file is as follows:

Index Number	LCR Mode
1 ~ 50	LCR.sda/LCR2.sda... in the root directory of internal files

Example:

:MMEM:STOR 1	Save LCR.sta file
:MMEM:STOR 9	Save LCR9.sta file
:MMEM:STOR 5, sss.sta	Save a file with the path sss.sta
:MMEM:STOR 5, files/sss.sta	Save a file with the path files/sss.sta
:MMEM:STOR 5, usb/sss.sta	Save a file with the path usb/sss.sta

7.2.19 SYSTEM Subsystem Commands

The SYSTem subsystem command set is mainly used to set system-related parameter functions.

7.2.19.1 Bus Mode

Used to set the command mode of the communication interface.

Command Syntax:

```
:SYST:BUSMODE?
```

```
:SYST:BUSMODE <RS232 | LAN | USBTMC | USBCDC | AUTO>
```

Parameter:

AUTO	Automatically select the communication interface
RS232 LAN USBTMC USBCDC	Lock the communication interface to a particular communication mode

Example:

:SYST:BUSMODE RS232	Set the bus communication as a fixed RS232 interface
:SYST:BUSMODE USB CDC	Set the bus communication as the fixed USB CDC interface
:SYST:BUSMODE AUTO	Set the bus communication to the automatic interface mode
:SYST:BUSMODE?	Return the current communication interface mode

7.2.19.2 Key Sound

Used to turn on/off the keypress sound.

Command Syntax:

```
:SYST:BEEP?
:SYST:BEEP <0 | 1 | OFF | ON>
```

Parameter:

0 OFF	OFF
1 ON	ON

Example:

:SYST:BEEP 0	Turn OFF the key sound
:SYST:BEEP 1	Turn ON the key sound
:SYST:BEEP?	Return the current key sound setup

7.2.19.3 PASS Sound

Used to set the PASS sound effect.

Command Syntax:

```
:SYST:BEEP:PASS?
:SYST:BEEP:PASS <OFF | TS | LL | HS | HL>
```

Parameter:

OFF	OFF
TS	Two short beeps
LL	Low long beep
HS	High short beep
HL	High long beep

Example:

:SYST:BEEP:PASS OFF	Turn OFF the PASS sound effect
:SYST:BEEP:PASS TS	Set the PASS sound to two short beeps
:SYST:BEEP:PASS HL	Set the PASS sound to high long beep
:SYST:BEEP:PASS?	Return the currently selected PASS sound effect

7.2.19.4 FAIL Sound

Used to set the FAIL sound effect.

Command Syntax:

```
:SYST:BEEP:FAIL?
```

```
:SYST:BEEP:FAIL <OFF | TS | LL | HS | HL>
```

Parameter:

OFF	OFF
TS	Two short beeps
LL	Low long beep
HS	High short beep
HL	High long beep

Example:

:SYST:BEEP:FAIL OFF	Turn OFF the FAIL sound effect
:SYST:BEEP:FAIL LL	Set the FAIL sound to low and long beep
:SYST:BEEP:FAIL HS	Set the FAIL sound to high and short beep
:SYST:BEEP:FAIL?	Return the currently selected FAIL sound effect

7.2.19.5 DateTime

Used to configure the system's time and date.

Command Syntax:

```
:SYST:DATETIME?
```

```
:SYST:DATETIME <year, month, day, hour, minute, second>
```

Parameter:

year	Value range 2018 ~ 2999
------	-------------------------

Example:

:SYST:DATETIME 2021, 11, 08, 12, 35, 56	Set the date and time to: 2021-11-08 12:35:56
:SYST:DATETIME?	Return the currently defined system time and date

7.2.19.6 RS232 Configuration: Baud Rate

Used to set the baud rate.

Command Syntax:

```
:SYST:RS232:BAUD?
```

```
:SYST:RS232:BAUD <4800 | 9600 | 19200 | 38400 | 57600 | 115200>
```

Example:

:SYST:RS232:BAUD 4800	Set the RS232 baud rate to 4800
:SYST:RS232:BAUD 38400	Set the RS232 baud rate to 38400
:SYST:RS232:BAUD 115200	Set the RS232 baud rate to 115200
:SYST:RS232:BAUD?	Return RS232 baud rate

7.2.19.7 RS232 Configuration: Bus Address

Used to set the instrument's bus address.

Command Syntax:

```
:SYST:RS232:ADDR?
:SYST:RS232:ADDR <1 ~ 32>
```

Example:

:SYST:RS232:ADDR 1	Set the instrument's bus address to 1
:SYST:RS232:ADDR 2	Set the instrument's bus address to 2
:SYST:RS232:ADDR 32	Set the instrument's bus address to 32
:SYST:RS232:ADDR?	Return the bus address of the instrument

7.2.19.8 Command Mode

Used to set the instrument's communication command mode.

Command Syntax:

```
:SYST:RS232:CMDMODE?
:SYST:RS232:CMDMODE <SCPI | MODBUS>
```

Example:

:SYST:RS232:CMDMODE SCPI	Set the instrument command mode to SCPI
:SYST:RS232:CMDMODE MODBUS	Set the command mode to MODBUS
:SYST:RS232:CMDMODE?	Return the command mode of the instrument

7.2.19.9 LAN Configuration: Port Number

Used to set the LAN port number.

Command Syntax:

```
:SYST:LAN:PORT?
:SYST:LAN:PORT <int>
```

Parameter:

int	Value range: consult the network management, recommended 1 ~ 65536; the factory default value is 45454
-----	--------------------------------------------------------------------------------------------------------

Example:

:SYST:LAN:PORT 45454 Set the port number of the LAN port to 45454
:SYST:LAN:PORT? Return the port number of the LAN port

7.2.19.10 LAN Configuration: Port DHCP

Used to set the LAN port DHCP.

Command Syntax:

:SYST:LAN:UDP

Example:

:SYST:LAN:UDP? Automatically obtain the network configuration

7.2.19.11 LAN Configuration: IP Address

Used to set the IP address of the LAN port.

Command Syntax:

:SYST:LAN:IPAD?
:SYST:LAN:IPAD <address>

Example:

:SYST:LAN:IPAD 192.168.22.209 Set the IP address of the LAN port to 192.168.22.209
:SYST:LAN:IPAD? Return the IP address of the LAN port

7.2.19.12 LAN Configuration: Gateway Address

Used to set the LAN port gateway address.

Command Syntax:

:SYST:LAN:GAT?
:SYST:LAN:GAT <address>

Example:

:SYST:LAN:GAT 192.168.22.1 Set the gateway address of the LAN port to 192.168.22.1
:SYST:LAN:GAT? Return gateway address of the LAN port

7.2.19.13 LAN Configuration: Subnet Mask Address

Used to set the subnet mask address of the LAN port.

Command Syntax:

:SYST:LAN:SMASK?
:SYST:LAN:SMASK <address>

Example:

:SYST:LAN:SMASK 255.255.255.0 Set the subnet mask address of the LAN port to 255.255.255.0

:SYST:LAN:SMASK? Return the subnet mask address of the LAN port

7.2.19.14 LAN Configuration: DNS Address

Used to set the DNS address of the LAN port.

Command Syntax:

:SYST:LAN:DNS?

:SYST:LAN:DNS <address₁>, <address₂>

Parameter:

address₁ Primary DNS address

address₂ Backup DNS address

Example:

:SYST:LAN:DNS 255.23.12.0, 255.23.14.1 Set the DNS address of the LAN port to 255.23.12.0 (and backup: 255.23.14.1)

:SYST:LAN:DNS? Return the DNS address of the LAN port

7.2.19.15 LAN Configuration: MAC Address

Used to query the MAC address of the LAN port.

Command Syntax:

:SYST:LAN:MAC?

Example:

:SYST:LAN:MAC? Return the MAC address of the LAN port

7.2.19.16 Update Command

Used to update the system firmware.

Command Syntax:

:SYST:UPDATE APP

Example:

:SYST:UPDATE APP Call the default file in the USB flash drive to upgrade

Note: In addition, we have the software for the host computer to control the firmware update of the instrument, which can directly send the update file from the host computer and perform the update without the need for a USB flash drive. The issued update file is stored by default in the internal storage of the instrument, such as update2840.sec. Considering that later update files may be relatively large, you can delete this file periodically.

7.3 Modbus Commands

7.3.1 Write Command Format

The command format is the internal version 2.0 standard; please refer to the following description for details.

7.3.1.1 Sending Format

Instrument address	Function code	High address	Low address	High registers	Low registers	Total number of bytes	Data byte 1	Data byte n	CRC Low	CRC High
--------------------	---------------	--------------	-------------	----------------	---------------	-----------------------	-------------	-------	-------------	---------	----------

7.3.1.2 Return Format

Instrument address	Function code	High address	Low address	High registers	Low registers	CRC Low	CRC High
--------------------	---------------	--------------	-------------	----------------	---------------	---------	----------

- Instrument Address:**
 This refers to the local address of the instrument, which can be set in the bus address of the instrument's system setting interface. The value range is 1 ~ 31.
- Function Code:**
 This command can write one or multiple sets of data, so its code is **0x10**.
- High Address and Low Address:**
 This refers to the storage address of the data in the instrument, which can be a real storage address or a mapped address.
- High Registers and Low Registers:**
 This indicates that the number of registers written in this operation and the size of each register is 2 bytes.
- Total Number of Bytes:**
 This represents the total number of bytes written in this operation.
- Data byte 1 ~ Data Byte n:**
 Write these data content to the instrument.
- CRC High and CRC Low:**
 CRC 16-bit check, we use the look-up table method for CRC check.

Example: The specific instruction and function setting relationship is detailed in the Appendix Table ModBus command function comparison table (Section 7.3.3)

Assume you set the voltage range to **range 2** (ie 300 V); the storage address of voltage range parameter in the instrument is **0x0003**, and the instrument bus address is **8**.

Then the command is:

0x08	0x10	0x00	0x03	0x00	0x01	0x01	0x02	C5	FD
------	------	------	------	------	------	------	------	----	----

Where, the countdown 3rd is corresponding to **20 %** index value of voltage, the type is **char** and accounting for **1** byte.

The return information is as follows:

0x08	0x10	0x00	0x03	0x00	0x01	0XF1	0x50
------	------	------	------	------	------	------	------

7.3.2 Read Command Format

7.3.2.1 Sending Format

Instrument address	Function code	High address	Low address	High registers	Low registers	CRC Low	CRC High
--------------------	---------------	--------------	-------------	----------------	---------------	---------	----------

7.3.2.2 Return Format

Instrument address	Function code	Total number of bytes	Data byte 1	Data byte n	CRC Low	CRC High
--------------------	---------------	-----------------------	-------------	-------	-------------	---------	----------

The function code is: **0x03**

Example: The specific instruction and function setting relationship is detailed in the Appendix Table ModeBus command function comparison table (Section 7.3.3);

To read the test value of the voltage in the current mode, the storage address is **0x00A0**, the instrument number is **8**.

Then the command is:

0x08	0x03	0x00	0xA0	0x00	0x02	0xC4	0xB0
------	------	------	------	------	------	------	------

The return information is as follows:

0x08	0x03	0x04	Data byte 1	Data byte 4	CRC Low	CRC High
------	------	------	-------------	-------	-------------	---------	----------

7.3.3 CRC16 Calculation Method – Look-Up Table Method

1) Define two 256-byte checklists:

High Byte Value Table:

```
const BYTE chCRCHTable[] = //CRC high byte value table
{
0x00, 0xC1, 0x81, 0x40, 0x01, 0xC0, 0x80, 0x41, 0x01, 0xC0, 0x80, 0x41,
0x00, 0xC1, 0x81, 0x40, 0x01, 0xC0, 0x80, 0x41, 0x00, 0xC1, 0x81, 0x40,
0x00, 0xC1, 0x81, 0x40, 0x01, 0xC0, 0x80, 0x41, 0x01, 0xC0, 0x80, 0x41,
0x00, 0xC1, 0x81, 0x40, 0x00, 0xC1, 0x81, 0x40, 0x01, 0xC0, 0x80, 0x41,
0x00, 0xC1, 0x81, 0x40, 0x01, 0xC0, 0x80, 0x41, 0x01, 0xC0, 0x80, 0x41,
0x00, 0xC1, 0x81, 0x40, 0x01, 0xC0, 0x80, 0x41, 0x00, 0xC1, 0x81, 0x40,
0x00, 0xC1, 0x81, 0x40, 0x01, 0xC0, 0x80, 0x41, 0x00, 0xC1, 0x81, 0x40,
0x01, 0xC0, 0x80, 0x41, 0x01, 0xC0, 0x80, 0x41, 0x00, 0xC1, 0x81, 0x40,
0x00, 0xC1, 0x81, 0x40, 0x01, 0xC0, 0x80, 0x41, 0x01, 0xC0, 0x80, 0x41,
0x00, 0xC1, 0x81, 0x40, 0x01, 0xC0, 0x80, 0x41, 0x01, 0xC0, 0x80, 0x41,
0x00, 0xC1, 0x81, 0x40, 0x00, 0xC1, 0x81, 0x40, 0x01, 0xC0, 0x80, 0x41,
0x00, 0xC1, 0x81, 0x40, 0x01, 0xC0, 0x80, 0x41, 0x01, 0xC0, 0x80, 0x41,
0x00, 0xC1, 0x81, 0x40, 0x00, 0xC1, 0x81, 0x40, 0x01, 0xC0, 0x80, 0x41,
0x00, 0xC1, 0x81, 0x40, 0x01, 0xC0, 0x80, 0x41, 0x01, 0xC0, 0x80, 0x41,
0x00, 0xC1, 0x81, 0x40, 0x01, 0xC0, 0x80, 0x41, 0x00, 0xC1, 0x81, 0x40,
0x00, 0xC1, 0x81, 0x40, 0x01, 0xC0, 0x80, 0x41, 0x01, 0xC0, 0x80, 0x41,
```

```
0x00, 0xC1, 0x81, 0x40, 0x00, 0xC1, 0x81, 0x40, 0x01, 0xC0, 0x80, 0x41,
0x00, 0xC1, 0x81, 0x40, 0x01, 0xC0, 0x80, 0x41, 0x01, 0xC0, 0x80, 0x41,
0x00, 0xC1, 0x81, 0x40
};
```

Low Byte Value Table:

```
const BYTE chCRCLTalbe[] =
{
0x00, 0xC0, 0xC1, 0x01, 0xC3, 0x03, 0x02, 0xC2, 0xC6, 0x06, 0x07, 0xC7,
0x05, 0xC5, 0xC4, 0x04, 0xCC, 0x0C, 0x0D, 0xCD, 0x0F, 0xCF, 0xCE, 0x0E,
0x0A, 0xCA, 0xCB, 0x0B, 0xC9, 0x09, 0x08, 0xC8, 0xD8, 0x18, 0x19, 0xD9,
0x1B, 0xDB, 0xDA, 0x1A, 0x1E, 0xDE, 0xDF, 0x1F, 0xDD, 0x1D, 0x1C, 0xDC,
0x14, 0xD4, 0xD5, 0x15, 0xD7, 0x17, 0x16, 0xD6, 0xD2, 0x12, 0x13, 0xD3,
0x11, 0xD1, 0xD0, 0x10, 0xF0, 0x30, 0x31, 0xF1, 0x33, 0xF3, 0xF2, 0x32,
0x36, 0xF6, 0xF7, 0x37, 0xF5, 0x35, 0x34, 0xF4, 0x3C, 0xFC, 0xFD, 0x3D,
0xFF, 0x3F, 0x3E, 0xFE, 0xFA, 0x3A, 0x3B, 0xFB, 0x39, 0xF9, 0xF8, 0x38,
0x28, 0xE8, 0xE9, 0x29, 0xEB, 0x2B, 0x2A, 0xEA, 0xEE, 0x2E, 0x2F, 0xEF,
0x2D, 0xED, 0xEC, 0x2C, 0xE4, 0x24, 0x25, 0xE5, 0x27, 0xE7, 0xE6, 0x26,
0x22, 0xE2, 0xE3, 0x23, 0xE1, 0x21, 0x20, 0xE0, 0xA0, 0x60, 0x61, 0xA1,
0x63, 0xA3, 0xA2, 0x62, 0x66, 0xA6, 0xA7, 0x67, 0xA5, 0x65, 0x64, 0xA4,
0x6C, 0xAC, 0xAD, 0x6D, 0xAF, 0x6F, 0x6E, 0xAE, 0xAA, 0x6A, 0x6B, 0xAB,
0x69, 0xA9, 0xA8, 0x68, 0x78, 0xB8, 0xB9, 0x79, 0xBB, 0x7B, 0x7A, 0xBA,
0xBE, 0x7E, 0x7F, 0xBF, 0x7D, 0xBD, 0xBC, 0x7C, 0xB4, 0x74, 0x75, 0xB5,
0x77, 0xB7, 0xB6, 0x76, 0x72, 0xB2, 0xB3, 0x73, 0xB1, 0x71, 0x70, 0xB0,
0x50, 0x90, 0x91, 0x51, 0x93, 0x53, 0x52, 0x92, 0x96, 0x56, 0x57, 0x97,
0x55, 0x95, 0x94, 0x54, 0x9C, 0x5C, 0x5D, 0x9D, 0x5F, 0x9F, 0x9E, 0x5E,
0x5A, 0x9A, 0x9B, 0x5B, 0x99, 0x59, 0x58, 0x98, 0x88, 0x48, 0x49, 0x89,
0x4B, 0x8B, 0x8A, 0x4A, 0x4E, 0x8E, 0x8F, 0x4F, 0x8D, 0x4D, 0x4C, 0x8C,
0x44, 0x84, 0x85, 0x45, 0x87, 0x47, 0x46, 0x86, 0x82, 0x42, 0x43, 0x83,
0x41, 0x81, 0x80, 0x40
};
```

2) Calculate:

```
WORD CRC16(BYTE* pchMsg, WORD wDataLen)
{
    BYTE chCRCHi = 0xFF; // High CRC byte initialization
    BYTE chCRCLo = 0xFF; // Low CRC byte initialization
    WORD wIndex;          // Index in the CRC loop

    while (wDataLen--)
    {
        // Calculate CRC
        wIndex = chCRCLo ^ *pchMsg++;
        chCRCLo = chCRCHi ^ chCRCHTalbe[wIndex];
        chCRCHi = chCRCLTalbe[wIndex];
    }

    return ((chCRCHi << 8) | chCRCLo);
}
```

7.3.4 Command Function Comparison Table

7.3.4.1 General Measurement Settings

Instrument Bus Address	Function Code	Command Address	Number of Data Bytes	Data Number	Data Byte	Description																																				
Instrument Address	Read/Write (R/W)	High+Low	High+Low	Data Number	The Value Corresponding to the Address																																					
1 ~ 31	R	0x0000	–	–	–	Return the instrument IDN																																				
	R/W	0x0001	0x0001 ~ 0x0004	1 ~ 4	0x01 ~ 0x	Function; the values are as follows: <table border="1"> <tr><td>0</td><td>CP</td><td>6</td><td>X</td><td>12</td><td>Q</td></tr> <tr><td>1</td><td>CS</td><td>7</td><td>G</td><td>13</td><td>dZ</td></tr> <tr><td>2</td><td>LP</td><td>8</td><td>B</td><td>14</td><td>rZ</td></tr> <tr><td>3</td><td>LS</td><td>9</td><td>Z</td><td>15</td><td>dY</td></tr> <tr><td>4</td><td>RP</td><td>10</td><td>Y</td><td>16</td><td>rY</td></tr> <tr><td>5</td><td>RS</td><td>11</td><td>D</td><td>17</td><td>RD</td></tr> </table>	0	CP	6	X	12	Q	1	CS	7	G	13	dZ	2	LP	8	B	14	rZ	3	LS	9	Z	15	dY	4	RP	10	Y	16	rY	5	RS	11	D	17	RD
0	CP	6	X	12	Q																																					
1	CS	7	G	13	dZ																																					
2	LP	8	B	14	rZ																																					
3	LS	9	Z	15	dY																																					
4	RP	10	Y	16	rY																																					
5	RS	11	D	17	RD																																					
	R/W	0x0002	0x0004	4	float	Frequency																																				
	R/W	0x0003	0x0001	1	0 ~ 3	Speed <table border="1"> <tr><td>0</td><td>FAST</td></tr> <tr><td>1</td><td>MED</td></tr> <tr><td>2</td><td>SLOW</td></tr> <tr><td>3</td><td>SFAST</td></tr> </table>	0	FAST	1	MED	2	SLOW	3	SFAST																												
0	FAST																																									
1	MED																																									
2	SLOW																																									
3	SFAST																																									
	R/W	0x0004	0x0001	1	0 ~ 1	Trigger <table border="1"> <tr><td>0</td><td>CONT</td></tr> <tr><td>1</td><td>SINGLE</td></tr> </table>	0	CONT	1	SINGLE																																
0	CONT																																									
1	SINGLE																																									
	R/W	0x0005	0x0001	1	0 ~ 1	Constant Level <table border="1"> <tr><td>0</td><td>OFF</td></tr> <tr><td>1</td><td>ON</td></tr> </table>	0	OFF	1	ON																																
0	OFF																																									
1	ON																																									
	R/W	0x0006	0x0004	4	float	Trigger Delay: 0 ~ 60.000 s																																				
	R/W	0x0007	0x0004	4	float	Step Delay: 0 ~ 60.000 s																																				
	R/W	0x0008	0x0001	1	0 ~ 1	Voltage Monitoring <table border="1"> <tr><td>0</td><td>OFF</td></tr> <tr><td>1</td><td>ON</td></tr> </table>	0	OFF	1	ON																																
0	OFF																																									
1	ON																																									
	R/W	0x0009	0x0001	1	0 ~ 1	Current Monitoring <table border="1"> <tr><td>0</td><td>OFF</td></tr> <tr><td>1</td><td>ON</td></tr> </table>	0	OFF	1	ON																																
0	OFF																																									
1	ON																																									
	R/W	0x000A	0x0005	5	float+char	AC Level float + 0/1 (v / i)																																				
	R/W	0x000B	0x0001	1	0 ~ 14	AC Range <table border="1"> <tr><td>0</td><td>100k</td><td>5</td><td>2k</td><td>10</td><td>50</td></tr> <tr><td>1</td><td>50k</td><td>6</td><td>1k</td><td>11</td><td>20</td></tr> <tr><td>2</td><td>20k</td><td>7</td><td>500</td><td>12</td><td>10</td></tr> <tr><td>3</td><td>10k</td><td>8</td><td>200</td><td>13</td><td>0.1</td></tr> <tr><td>4</td><td>5k</td><td>9</td><td>100</td><td></td><td></td></tr> </table>	0	100k	5	2k	10	50	1	50k	6	1k	11	20	2	20k	7	500	12	10	3	10k	8	200	13	0.1	4	5k	9	100								
0	100k	5	2k	10	50																																					
1	50k	6	1k	11	20																																					
2	20k	7	500	12	10																																					
3	10k	8	200	13	0.1																																					
4	5k	9	100																																							
	R/W	0x000C	0x0005	5	float+char	DC Bias float + 0 / 1 (v / i)																																				
		0x000D	–	–	–	xx																																				
	R/W	0x000E	0x0001	1	1 ~ 256	Average																																				

	R/W	0x000F	0x0001	1	0 ~ 1	BIAS Polarity <table border="1"> <tr><td>0</td><td>OFF</td></tr> <tr><td>1</td><td>ON</td></tr> </table>	0	OFF	1	ON		
0	OFF											
1	ON											
	R/W	0x0010	0x0001	1	0 ~ 14	DC Range						
	R/W	0x0011	0x0004	4	float	DC Level						
		0x0012	-	-	-	xx						
	R/W	0x0013	0x0001	1	0 ~ 1	DC Isolation <table border="1"> <tr><td>0</td><td>OFF</td></tr> <tr><td>1</td><td>ON</td></tr> </table>	0	OFF	1	ON		
0	OFF											
1	ON											
	R/W	0x0014	0x0001	1	0 ~ 2	Deviation 1 <table border="1"> <tr><td>0</td><td>OFF</td></tr> <tr><td>1</td><td>ABS</td></tr> <tr><td>2</td><td>PER</td></tr> </table>	0	OFF	1	ABS	2	PER
0	OFF											
1	ABS											
2	PER											
	R/W	0x0015	0x0001	1	0 ~ 2	Deviation 2 <table border="1"> <tr><td>0</td><td>OFF</td></tr> <tr><td>1</td><td>ABS</td></tr> <tr><td>2</td><td>PER</td></tr> </table>	0	OFF	1	ABS	2	PER
0	OFF											
1	ABS											
2	PER											
	R/W	0x0016	0x0004	4	float	Reference 1						
	R/W	0x0017	0x0004	4	float	Reference 2						
	R/W	0x1000	0x0001	1	0 ~ 2	Deviation 3 <table border="1"> <tr><td>0</td><td>OFF</td></tr> <tr><td>1</td><td>ABS</td></tr> <tr><td>2</td><td>PER</td></tr> </table>	0	OFF	1	ABS	2	PER
0	OFF											
1	ABS											
2	PER											
	R/W	0x1001	0x0001	1	0 ~ 2	Deviation 4 <table border="1"> <tr><td>0</td><td>OFF</td></tr> <tr><td>1</td><td>ABS</td></tr> <tr><td>2</td><td>PER</td></tr> </table>	0	OFF	1	ABS	2	PER
0	OFF											
1	ABS											
2	PER											
	R/W	0x1002	0x0004	4	float	Reference 3						
	R/W	0x1003	0x0004	4	float	Reference 4						
	R/W	0x0019	4 × n	4 × n	float × n	Reference value, set 1 ~ 4 reference values The value of n is 1 ~ 4, that is, you can set 1, 2, 3 or 4 reference values at the same time						

7.3.4.2 Multi-Parameter Batch Setup

Function Code	Command Address	Number of Data Bytes	Data Number	Data Byte	Description
Read/Write (R/W)	High+Low	High+Low	Data Number	The Value Corresponding to the Address	
R/W	0x1020	n	2n	...	Batch read/write of measurement related parameter settings

The parameters of the n registers (1 ~ n) are as follows:

1	Function 1	11	AC Level Type	21	DC Range	31	DC Bias Type	41	Reference 1	51	Current Monitoring ON/OFF
2	Function 2	12	AC Voltage	22	Trigger Mode	32	DC Bias Voltage	42	Reference 2		
3	Function 3	13		23	Trigger Delay	33		43			
4	Function 4	14	AC Current	24	Step Delay	34	DC Bias Current	44	Reference 3		
5	F1 ON/OFF	15		25		35		45			
6	F2 ON/OFF	16	DC Level	26	Average Count	36	Mode 1 Deviation	46	Reference 4		
7	F3 ON/OFF	17		27	37	47					
8	F4 ON/OFF	18	Speed	28	Bias Source	38	Mode 3 Deviation	48	Constant Level ON/OFF		
9	Frequency	19	Auto Range ON/OFF	29	Bias Output Source	39	Mode 4 Deviation	49	DC Isolation		
10		20	AC Range	30	Bias Polarity	40	Reference 1	50	Voltage Monitoring ON/OFF		

Note:

- 1 register equals 2 bytes in length.
- Specific register parameter nomenclature and value ranges can be found in the previous part of this section or in the introduction related to the measurement setup parameters.
- The length of data corresponding to a write operation must be 2 times the number of registers.
- The number of registers to be read or written can be from 1 to 45, and the instrument response starts from 1 and cannot be read or written from the center.

Function Code	Command Address	Number of Data Bytes	Data Number	Data Byte	Description
Read/Write (R/W)	High+Low	High+Low	Data Number	The Value Corresponding to the Address	
R/W	0x1020	n	2n	...	Batch read/write of measurement related parameter settings

The parameters of the n registers (1 ~ n) are as follows:

1	Function 1	11	Auto Range ON/OFF	21	Deviation Mode 2	31	AC Voltage	41	DC Bias Voltage	51	Reference 4
2	Function 2	12	AC Range	22	Deviation Mode 3	32	AC Current	42	DC Bias Current		
3	Function 3	13	DC Range	23	Deviation Mode 4	33		43			
4	Function 4	14	Trigger Mode	24	Constant Level ON/OFF	34	DC Level	44	Reference 1		
5	F1 ON/OFF	15	Average Count	25	DC Isolation	35		45			
6	F2 ON/OFF	16	Bias Source	26	Voltage Monitoring ON/OFF	36	Trigger Delay	46	Reference 2		
7	F3 ON/OFF	17	Bias Output Source	27	Current Monitoring ON/OFF	37		47			
8	F4 ON/OFF	18	Bias Polarity	28	Frequency	38	Step Delay	48	Reference 3		
9	AC Level Type	19	DC Bias Type	29		39		49			
10	Speed	20	Bias Mode 1	30	AC Voltage	40	DC Bias Voltage	50	Reference 4		

Note:

- 1 register equals 2 bytes in length.
- Specific register parameter nomenclature and value ranges can be found in the previous part of this section or in the introduction related to the measurement setup parameters.
- The length of data corresponding to a write operation must be 2 times the number of registers.
- The number of registers to be read or written can be from 1 to 45, and the instrument response starts from 1 and cannot be read or written from the center.

7.3.4.3 Comparison Settings

Instrument Bus Address	Function Code	Command Address	Number of Data Bytes	Data Number	Data Byte	Description				
Instrument Address	Read/Write (R/W)	High+Low	High+Low	Data Number	The Value Corresponding to the Address					
	R/W	0x001C	0x0001	1	0 ~ 1	Comparison Function <table border="1"> <tr> <td>0</td> <td>OFF</td> </tr> <tr> <td>1</td> <td>ON</td> </tr> </table>	0	OFF	1	ON
0	OFF									
1	ON									
	R/W	0x001D	0x0004	4	float	BIN 1 Low				
	R/W	0x001E	0x0004	4	float	BIN 1 High				
	R/W	0x001F	0x0004	4	float	BIN 2 Low				
	R/W	0x0020	0x0004	4	float	BIN 2 High				
	R/W	0x0021	0x0004	4	float	BIN 3 Low				
	R/W	0x0022	0x0004	4	float	BIN 3 High				
	R/W	0x0023	0x0004	4	float	BIN 4 Low				
	R/W	0x0024	0x0004	4	float	BIN 4 High				
	R/W	0x0025	0x0004	4	float	BIN 5 Low				
	R/W	0x0026	0x0004	4	float	BIN 5 High				
	R/W	0x0027	0x0004	4	float	BIN 6 Low				
	R/W	0x0028	0x0004	4	float	BIN 6 High				
	R/W	0x0029	0x0004	4	float	BIN 7 Low				
	R/W	0x002A	0x0004	4	float	BIN 7 High				
	R/W	0x002B	0x0004	4	float	BIN 8 Low				
	R/W	0x002C	0x0004	4	float	BIN 8 High				
	R/W	0x002D	0x0004	4	float	BIN 9 Low				
	R/W	0x002E	0x0004	4	float	BIN 9 High				
	R/W	0x002F	0x0004	4	float	BIN 10 Low				
	R/W	0x0030	0x0004	4	float	BIN 10 High				
	R/W	0x1004	0x0006	6	char+ char+ float	BIN 1 ~ 10 Low <ul style="list-style-type: none"> BIN index 0 ~ 9; abcd index 0 ~ 3 float is the value 				
	R/W	0x1005	0x0006	6		BIN 1 ~ 10 High <ul style="list-style-type: none"> BIN index 0 ~ 9 abcd index 0 ~ 3 float is the value 				

7.3.4.4 List Settings

Instrument Bus Address	Function Code	Command Address	Number of Data Bytes	Data Number	Data Byte	Description																																				
Instrument Address	Read/Write (R/W)	High+Low	High+Low	Data Number	The Value Corresponding to the Address																																					
	R/W	0x0050	0x0001	1	1 ~ 201	List Sweep Point																																				
	R/W	0x0051	0x0001	1	0 ~ 1	List Sweep Mode <table border="1"> <tr> <td>0</td> <td>SEQ</td> </tr> <tr> <td>1</td> <td>STEP</td> </tr> </table>	0	SEQ	1	STEP																																
0	SEQ																																									
1	STEP																																									
	R/W	0x0052	–	–	–	–																																				
	R/W	0x0053	0x0001	1	0 ~ 200	The sweep point index position in the current setup																																				
	R/W	0x0054	–	–	–	–																																				
	R/W	0x0055	0x0004	4	float	List Scan Point Frequency																																				
	R/W	0x0056	0x0005	5	float+u16	List Scan Point AC Level +0/1(v/i)																																				
	R/W	0x0057	–	–	–	–																																				
	R/W	0x0058	0x0005	5	float+u16	List Scan Point DC Bias +0/1(v/i)																																				
	R/W	0x005A	0x0001 ~ 0x0004	1 ~ 4	0 ~	Function; the values are as follows: <table border="1"> <tr> <td>0</td> <td>CP</td> <td>6</td> <td>X</td> <td>12</td> <td>Q</td> </tr> <tr> <td>1</td> <td>CS</td> <td>7</td> <td>G</td> <td>13</td> <td>dZ</td> </tr> <tr> <td>2</td> <td>LP</td> <td>8</td> <td>B</td> <td>14</td> <td>rZ</td> </tr> <tr> <td>3</td> <td>LS</td> <td>9</td> <td>Z</td> <td>15</td> <td>dY</td> </tr> <tr> <td>4</td> <td>RP</td> <td>10</td> <td>Y</td> <td>16</td> <td>rY</td> </tr> <tr> <td>5</td> <td>RS</td> <td>11</td> <td>D</td> <td>17</td> <td>RD</td> </tr> </table>	0	CP	6	X	12	Q	1	CS	7	G	13	dZ	2	LP	8	B	14	rZ	3	LS	9	Z	15	dY	4	RP	10	Y	16	rY	5	RS	11	D	17	RD
0	CP	6	X	12	Q																																					
1	CS	7	G	13	dZ																																					
2	LP	8	B	14	rZ																																					
3	LS	9	Z	15	dY																																					
4	RP	10	Y	16	rY																																					
5	RS	11	D	17	RD																																					
	R/W	0x005C	0x0004	4	float	List Scan Point Step Delay																																				
	R/W	0x1006	0x0006	6	char+ char+ float	Low Limit <ul style="list-style-type: none"> point index 0 ~ 200 abcd index 0 ~ 3 float is the value 																																				
	R/W	0x1007	0x0006	6		High Limit <ul style="list-style-type: none"> point index 0 ~ 200 abcd index 0 ~ 3 float is the value 																																				
	R	0x100B	9 × n	–	–	Rest List All Test Results <ul style="list-style-type: none"> The number of registers read is n × 9 (i.e., n points) The data for a single point is composed as follows: <table border="1"> <tr> <td>2Reg</td> <td>2Reg</td> <td>2Reg</td> <td>2Reg</td> <td>1Reg</td> </tr> <tr> <td>P₁</td> <td>P₂</td> <td>P₃</td> <td>P₄</td> <td>cmp</td> </tr> </table> 	2Reg	2Reg	2Reg	2Reg	1Reg	P ₁	P ₂	P ₃	P ₄	cmp																										
2Reg	2Reg	2Reg	2Reg	1Reg																																						
P ₁	P ₂	P ₃	P ₄	cmp																																						
	R	0x100C 0x100D 0x100E	2 × n	–	–	Read List Specified Parameters 1/2/3/4 Test Results																																				

		0x100F				<ul style="list-style-type: none"> The number of registers read is $n \times 2$ (i.e., n points) The data of a single point is composed as follows: <table border="1" style="margin-left: 20px;"> <tr><td>2Reg</td></tr> <tr><td>P_n</td></tr> </table> 	2Reg	P_n								
2Reg																
P_n																
	R	0x1010	n	-	-	<p>Read List Comparison Results</p> <ul style="list-style-type: none"> Reading the number of registers as n (i.e. n points) The data of a single point is composed as follows: cmp <p>Values:</p> <p>0 not compared 1 PASS Others FAIL</p> <table border="1" style="margin-left: 20px;"> <tr><td>1Reg</td></tr> <tr><td>cmp</td></tr> </table>	1Reg	cmp								
1Reg																
cmp																
	R	0x1011	4	8	Short (0 ~ 3)	<p>Setting the Data Size Returned by the 4 Parameters of the List</p> <ul style="list-style-type: none"> The 4 words correspond to the 4-parameter report size <p>Values:</p> <p>0 default absolute data size 1 data $\times 10^3$ after reporting 2 data $\times 10^6$ after reporting</p> <p>Example:</p> <p>Write 08 10 10 11 00 04 08 00 00 00 00 00 00 00 00 00 7D D0 — Set all 4 parameters to 0</p> <p>Write 08 10 10 11 00 04 08 00 01 00 01 00 01 00 01 00 01 C0 D0 ---- Set all 4 parameters to 1</p> <p>Write 08 10 10 11 00 04 08 00 02 00 02 00 02 00 02 00 02 07 D1 ---- Set all 4 parameters to 2</p>										
	R/W	0x3000	W(1+2n) R(2n)	W(1+2n) R(2n)	W(u16)+ n ↑ float	<p>Batch Read and Write:</p> <p>List Scan Point Frequency</p> <ul style="list-style-type: none"> Write register starts at pt; read register starts at 0 The first register, $u16$, indicates the start point index, pt, with a value from 0 to 200. <p>The data of the write register is composed as follows:</p> <table border="1" style="margin-left: 20px;"> <tr> <td>1Reg</td> <td>2Reg</td> <td>2Reg</td> <td>...</td> <td>2Reg</td> </tr> <tr> <td>Starting pt</td> <td>f[pt]</td> <td>f[pt+1]</td> <td>...</td> <td>f[pt+n-1]</td> </tr> </table> <p>The data of the read register is composed as follows:</p>	1Reg	2Reg	2Reg	...	2Reg	Starting pt	f[pt]	f[pt+1]	...	f[pt+n-1]
1Reg	2Reg	2Reg	...	2Reg												
Starting pt	f[pt]	f[pt+1]	...	f[pt+n-1]												

						2Reg	2Reg	...	2Reg								
						f[0]	f[1]	...	f[n-1]								
	R/W	0x3001	W(1+2n) R(2n)	W(1+2n) R(2n)	W(u16)+ n ↑ float	Batch Read and Write: Scan Point Level Voltage Read and Write Description is the same as that for address 0x3000.											
	R/W	0x3002	W(1+2n) R(2n)	W(1+2n) R(2n)	W(u16)+ n ↑ float	Batch Read and Write: Scan Point Level Current Read and Write Description is the same as that for address 0x3000.											
	R/W	0x3003	W(1+2n) R(2n)	W(1+2n) R(2n)	W(u16)+ n ↑ float	Batch Read and Write: Scan Point Offset Voltage Read and Write Description is the same as that for address 0x3000.											
	R/W	0x3004	W(1+2n) R(2n)	W(1+2n) R(2n)	W(u16)+ n ↑ float	Batch Read and Write: Scan Point Offset Current Read and Write Description is the same as that for address 0x3000.											
	R/W	0x3005	W(1+2n) R(2n)	W(1+2n) R(2n)	W(u16)+ n ↑ float	Batch Read and Write: Scan Point Step Delay Read and Write Description is the same as that for address 0x3000.											
	R/W	0x3006 0x3007 0x3008 0x3009	W(1+2n) R(2n)	W(1+2n) R(2n)	W(u16)+ n ↑ float	Batch Read and Write: Scan Point Upper Limits Addresses correspond to four parameters as follows: <table border="1" style="margin: 10px auto;"> <tr> <td>0x3006</td> <td>0x3007</td> <td>0x3008</td> <td>0x3009</td> </tr> <tr> <td>Parameter 1 (A)</td> <td>Parameter 2 (B)</td> <td>Parameter 3 (C)</td> <td>Parameter 4 (D)</td> </tr> </table> Read and Write Description is otherwise the same as that for address 0x3000.				0x3006	0x3007	0x3008	0x3009	Parameter 1 (A)	Parameter 2 (B)	Parameter 3 (C)	Parameter 4 (D)
0x3006	0x3007	0x3008	0x3009														
Parameter 1 (A)	Parameter 2 (B)	Parameter 3 (C)	Parameter 4 (D)														
	R/W	0x300A 0x300B 0x300C 0x300D	W(1+2n) R(2n)	W(1+2n) R(2n)	W(u16)+ n ↑ float	Batch Read and Write: Scan Point Lower Limits Addresses correspond to four parameters as follows: <table border="1" style="margin: 10px auto;"> <tr> <td>0x300A</td> <td>0x300B</td> <td>0x300C</td> <td>0x300D</td> </tr> <tr> <td>Parameter 1 (A)</td> <td>Parameter 2 (B)</td> <td>Parameter 3 (C)</td> <td>Parameter 4 (D)</td> </tr> </table> Read and Write Description is otherwise the same as that for address 0x3000.				0x300A	0x300B	0x300C	0x300D	Parameter 1 (A)	Parameter 2 (B)	Parameter 3 (C)	Parameter 4 (D)
0x300A	0x300B	0x300C	0x300D														
Parameter 1 (A)	Parameter 2 (B)	Parameter 3 (C)	Parameter 4 (D)														

						<p>Batch Read and Write:</p> <p>Scan Point Function</p> <p>Addresses correspond to four parameters as follows:</p> <table border="1"> <tr> <td>0x300E</td> <td>0x300F</td> <td>0x3010</td> <td>0x3011</td> </tr> <tr> <td>Parameter 1 (A)</td> <td>Parameter 2 (B)</td> <td>Parameter 3 (C)</td> <td>Parameter 4 (D)</td> </tr> </table> <p>(Write registers start at point pt; read registers start at point 0)</p> <p>The first register u16 indicates the starting point index pt and takes the value 0 ~ 200.</p> <p>The data of the write register is composed as follows:</p> <table border="1"> <tr> <td>1Reg</td> <td>1Reg</td> <td>1Reg</td> <td>...</td> <td>1Reg</td> </tr> <tr> <td>Starting pt</td> <td>func[pt]</td> <td>func[pt+1]</td> <td>...</td> <td>func[pt+n-1]</td> </tr> </table> <p>The data of the read register is composed as follows:</p> <table border="1"> <tr> <td>2Reg</td> <td>2Reg</td> <td>...</td> <td>2Reg</td> </tr> <tr> <td>func[0]</td> <td>func[1]</td> <td>...</td> <td>func[n-1]</td> </tr> </table> <p>Function with the following parameter cross-reference:</p> <table border="1"> <tr> <td>0</td> <td>CP</td> <td>6</td> <td>X</td> <td>12</td> <td>Q</td> </tr> <tr> <td>1</td> <td>CS</td> <td>7</td> <td>G</td> <td>13</td> <td>dZ</td> </tr> <tr> <td>2</td> <td>LP</td> <td>8</td> <td>B</td> <td>14</td> <td>rZ</td> </tr> <tr> <td>3</td> <td>LS</td> <td>9</td> <td>Z</td> <td>15</td> <td>dY</td> </tr> <tr> <td>4</td> <td>RP</td> <td>10</td> <td>Y</td> <td>16</td> <td>rY</td> </tr> <tr> <td>5</td> <td>RS</td> <td>11</td> <td>D</td> <td>17</td> <td>RD</td> </tr> </table>	0x300E	0x300F	0x3010	0x3011	Parameter 1 (A)	Parameter 2 (B)	Parameter 3 (C)	Parameter 4 (D)	1Reg	1Reg	1Reg	...	1Reg	Starting pt	func[pt]	func[pt+1]	...	func[pt+n-1]	2Reg	2Reg	...	2Reg	func[0]	func[1]	...	func[n-1]	0	CP	6	X	12	Q	1	CS	7	G	13	dZ	2	LP	8	B	14	rZ	3	LS	9	Z	15	dY	4	RP	10	Y	16	rY	5	RS	11	D	17	RD
0x300E	0x300F	0x3010	0x3011																																																																	
Parameter 1 (A)	Parameter 2 (B)	Parameter 3 (C)	Parameter 4 (D)																																																																	
1Reg	1Reg	1Reg	...	1Reg																																																																
Starting pt	func[pt]	func[pt+1]	...	func[pt+n-1]																																																																
2Reg	2Reg	...	2Reg																																																																	
func[0]	func[1]	...	func[n-1]																																																																	
0	CP	6	X	12	Q																																																															
1	CS	7	G	13	dZ																																																															
2	LP	8	B	14	rZ																																																															
3	LS	9	Z	15	dY																																																															
4	RP	10	Y	16	rY																																																															
5	RS	11	D	17	RD																																																															
	R/W	0x300E 0x300F 0x3010 0x3011	W(1+n) R(n)	W(1+n) R(n)	W(u16)+ n ↑ u16																																																															

7.3.4.5 Curve Settings

Instrument Bus Address	Function Code	Command Address	Number of Data Bytes	Data Number	Data Byte	Description				
Instrument Address	Read/Write (R/W)	High+Low	High+Low	Data Number	The Value Corresponding to the Address					
	R/W	0x0090	0x0001	1	0 ~ 1	LCR Curve: Scale <table border="1"> <tr> <td>0</td> <td>AUTO</td> </tr> <tr> <td>1</td> <td>HOLD</td> </tr> </table>	0	AUTO	1	HOLD
0	AUTO									
1	HOLD									
	R/W	0x0092	0x0001	1	0 ~ 1	LCR Curve: Coordinate <table border="1"> <tr> <td>0</td> <td>Linear</td> </tr> <tr> <td>1</td> <td>Logarithmic</td> </tr> </table>	0	Linear	1	Logarithmic
0	Linear									
1	Logarithmic									
	R/W	0x0094	0x0001	1	0 ~ 1	LCR Curve: Mode <table border="1"> <tr> <td>0</td> <td>SEQ</td> </tr> <tr> <td>1</td> <td>STEP</td> </tr> </table>	0	SEQ	1	STEP
0	SEQ									
1	STEP									

	R/W	0x0096	0x0001	1	0 ~ 4	LCR Curve: Points <table border="1"> <tr><td>0</td><td>51</td></tr> <tr><td>1</td><td>101</td></tr> <tr><td>2</td><td>201</td></tr> <tr><td>3</td><td>401</td></tr> <tr><td>4</td><td>801</td></tr> </table>	0	51	1	101	2	201	3	401	4	801
0	51															
1	101															
2	201															
3	401															
4	801															
	R/W	0x0097	0x0001	1	0 ~ 1	LCR Trace: Max-Min <table border="1"> <tr><td>0</td><td>OFF</td></tr> <tr><td>1</td><td>ON</td></tr> </table>	0	OFF	1	ON						
0	OFF															
1	ON															
	R/W	0x0098	0x0001	1	0 ~ 4	LCR Curve: Start Size										
	R/W	0x0099	0x0001	1	0 ~ 4	LCR Curve: Stop Size										

7.3.4.6 User Correction Settings

Instrument Bus Address	Function Code	Command Address	Number of Data Bytes	Data Number	Data Byte	Description										
Instrument Address	Read/Write (R/W)	High+Low	High+Low	Data Number	The Value Corresponding to the Address											
	R/W	0x0031	0x0001	2	0 ~ 1	Open-Circuit Correction <table border="1"> <tr><td>0</td><td>OFF</td></tr> <tr><td>1</td><td>ON</td></tr> <tr><td>2</td><td>Full Freq Open-Circuit Correction</td></tr> <tr><td>3</td><td>DCR Correction</td></tr> </table>	0	OFF	1	ON	2	Full Freq Open-Circuit Correction	3	DCR Correction		
0	OFF															
1	ON															
2	Full Freq Open-Circuit Correction															
3	DCR Correction															
	R/W	0x0032	0x0001	2	0 ~ 1	Short-Circuit Correction <table border="1"> <tr><td>0</td><td>OFF</td></tr> <tr><td>1</td><td>ON</td></tr> <tr><td>2</td><td>Full Freq Short-Circuit Correction</td></tr> <tr><td>3</td><td>DCR Correction</td></tr> </table>	0	OFF	1	ON	2	Full Freq Short-Circuit Correction	3	DCR Correction		
0	OFF															
1	ON															
2	Full Freq Short-Circuit Correction															
3	DCR Correction															
	R/W	0x0033	0x0001	2	0 ~ 1	Load Correction Function										
	R/W	0x0034	0x0001	2	0 ~ 1	Cable Length										
	R/W	0x0035	–	–	–	–										
	R/W	0x0036	0x0001	2	0 ~ 9	Calibration Point										
	R/W	0x0037	0x0004	4	float	Frequency Setup										
	R/W	0x0038	0x0001	2	0 ~ 4	Frequency Point ON/OFF <table border="1"> <tr><td>0</td><td>OFF</td></tr> <tr><td>1</td><td>ON</td></tr> <tr><td>2</td><td>Single Freq Open-Circuit Correction</td></tr> <tr><td>3</td><td>Single Freq Short-Circuit Correction</td></tr> <tr><td>4</td><td>Single Freq Load Correction</td></tr> </table>	0	OFF	1	ON	2	Single Freq Open-Circuit Correction	3	Single Freq Short-Circuit Correction	4	Single Freq Load Correction
0	OFF															
1	ON															
2	Single Freq Open-Circuit Correction															
3	Single Freq Short-Circuit Correction															
4	Single Freq Load Correction															
	R/W	0x0039	0x0004	4	float	Reference A for Calibration Point										
	R/W	0x003A	0x0004	4	float	Reference B for Calibration Point										

7.3.4.7 System Settings

Instrument Bus Address	Function Code	Command Address	Number of Data Bytes	Data Number	Data Byte	Description																																																								
Instrument Address	Read/Write (R/W)	High+Low	High+Low	Data Number	The Value Corresponding to the Address																																																									
	W	0x0040	0x0001	1	1	Start Test (Trigger Key Function)																																																								
	W	0x0041	0x0001	1	1	Stop Test (Reset Key Function)																																																								
	R	0x0042	–	–	–	Read the Results																																																								
	R/W	0x0043	0x0001	1	char	Page Switching; value range of the parameters is as follows: <table border="1" data-bbox="997 667 1439 1137"> <tr><td>0</td><td>Measurement</td><td>1</td><td>List</td></tr> <tr><td>2</td><td>LCR</td><td>3</td><td>Measurement Settings</td></tr> <tr><td>4</td><td>Limit Settings</td><td>5</td><td>List Settings</td></tr> <tr><td>6</td><td>LCR Settings</td><td>7</td><td>System Settings</td></tr> <tr><td>8</td><td>File Management</td><td>9</td><td>User Corrections</td></tr> <tr><td>10</td><td>Handler</td><td></td><td></td></tr> <tr><td>11</td><td>Single Test</td><td>12</td><td>Single Test Settings</td></tr> <tr><td>15</td><td>TRS Scan</td><td>16</td><td>TRS ID</td></tr> <tr><td>17</td><td>Pin to Fixture</td><td>18</td><td>1831 Scan</td></tr> <tr><td>19</td><td>1901 Scan</td><td>20</td><td>Pin Settings</td></tr> <tr><td>21</td><td>Condition Setting</td><td>22</td><td>Deviation Deduction</td></tr> <tr><td>23</td><td>Quick Setup</td><td>24</td><td>Statistics</td></tr> <tr><td>25</td><td>Tools</td><td>26</td><td>Scanning Self-Test</td></tr> <tr><td>27</td><td>Scan Hand</td><td></td><td></td></tr> </table>	0	Measurement	1	List	2	LCR	3	Measurement Settings	4	Limit Settings	5	List Settings	6	LCR Settings	7	System Settings	8	File Management	9	User Corrections	10	Handler			11	Single Test	12	Single Test Settings	15	TRS Scan	16	TRS ID	17	Pin to Fixture	18	1831 Scan	19	1901 Scan	20	Pin Settings	21	Condition Setting	22	Deviation Deduction	23	Quick Setup	24	Statistics	25	Tools	26	Scanning Self-Test	27	Scan Hand		
0	Measurement	1	List																																																											
2	LCR	3	Measurement Settings																																																											
4	Limit Settings	5	List Settings																																																											
6	LCR Settings	7	System Settings																																																											
8	File Management	9	User Corrections																																																											
10	Handler																																																													
11	Single Test	12	Single Test Settings																																																											
15	TRS Scan	16	TRS ID																																																											
17	Pin to Fixture	18	1831 Scan																																																											
19	1901 Scan	20	Pin Settings																																																											
21	Condition Setting	22	Deviation Deduction																																																											
23	Quick Setup	24	Statistics																																																											
25	Tools	26	Scanning Self-Test																																																											
27	Scan Hand																																																													
	R/W	0x0045	0x0001	1	0 ~ 1	Keypress Sound <table border="1" data-bbox="997 1205 1439 1265"> <tr><td>0</td><td>OFF</td></tr> <tr><td>1</td><td>ON</td></tr> </table>	0	OFF	1	ON																																																				
0	OFF																																																													
1	ON																																																													
	R/W	0x0045	0x0001	1	0 ~ 4	Pass Sound <table border="1" data-bbox="997 1332 1439 1482"> <tr><td>0</td><td>OFF</td></tr> <tr><td>1</td><td>Two Short</td></tr> <tr><td>2</td><td>Two High</td></tr> <tr><td>3</td><td>High Short</td></tr> <tr><td>4</td><td>High Long</td></tr> </table>	0	OFF	1	Two Short	2	Two High	3	High Short	4	High Long																																														
0	OFF																																																													
1	Two Short																																																													
2	Two High																																																													
3	High Short																																																													
4	High Long																																																													
	R/W	0x0045	0x0001	1	0 ~ 4	Fail Sound <table border="1" data-bbox="997 1550 1439 1700"> <tr><td>0</td><td>OFF</td></tr> <tr><td>1</td><td>Two Short</td></tr> <tr><td>2</td><td>Two High</td></tr> <tr><td>3</td><td>High Short</td></tr> <tr><td>4</td><td>High Long</td></tr> </table>	0	OFF	1	Two Short	2	Two High	3	High Short	4	High Long																																														
0	OFF																																																													
1	Two Short																																																													
2	Two High																																																													
3	High Short																																																													
4	High Long																																																													
	R/W	0x0045	0x0001	1	0 ~ 1	Language <table border="1" data-bbox="997 1767 1439 1827"> <tr><td>0</td><td>English</td></tr> <tr><td>1</td><td>Chinese</td></tr> </table>	0	English	1	Chinese																																																				
0	English																																																													
1	Chinese																																																													
	R/W	0x004E	0x0001	1	0 ~ 2	Bias Source <table border="1" data-bbox="997 1895 1439 1998"> <tr><td>0</td><td>100 mA</td></tr> <tr><td>1</td><td>2 A</td></tr> <tr><td>2</td><td>External ST1778</td></tr> </table>	0	100 mA	1	2 A	2	External ST1778																																																		
0	100 mA																																																													
1	2 A																																																													
2	External ST1778																																																													

7.3.4.8 File Management Settings

Instrument Bus Address	Function Code	Command Address	Number of Data Bytes	Data Number	Data Byte	Description				
Instrument Address	Read/Write (R/W)	High+Low	High+Low	Data Number	The Value Corresponding to the Address					
	W	0x1008	0x0001	1	char (0 ~ 1)	Save Test Result to USB <table border="1"> <tr> <td>0</td> <td>OFF</td> </tr> <tr> <td>1</td> <td>ON</td> </tr> </table>	0	OFF	1	ON
0	OFF									
1	ON									
	W	0x1009	0x0001	1	char (0 ~ 1)	Save List Results to USB <table border="1"> <tr> <td>0</td> <td>OFF</td> </tr> <tr> <td>1</td> <td>ON</td> </tr> </table>	0	OFF	1	ON
0	OFF									
1	ON									
	W	0x100A	0x0001	1	char (0 ~ 1)	Save Curve Results to USB <table border="1"> <tr> <td>0</td> <td>OFF</td> </tr> <tr> <td>1</td> <td>ON</td> </tr> </table>	0	OFF	1	ON
0	OFF									
1	ON									
	R/W	0x2005	0x0001	2	char(0 ~ 50)	Load the specified file in the internal files directory. The value of n ranges from 0 to 50. Specifies a file in the files root directory in the following format: <table border="1"> <tr> <td>LCR Bridge</td> <td>LCR1.sta, LCR2.sta, LCR3.sta, LCRn.sta</td> </tr> </table> Reading this register means querying whether an internal file has been loaded, and if so, returning the size of n (2 bytes in length) corresponding to its presence in the data. If there is no internal file being loaded, then no n is returned, and the return is: 08 03 00 F0 F2	LCR Bridge	LCR1.sta, LCR2.sta, LCR3.sta, LCRn.sta		
LCR Bridge	LCR1.sta, LCR2.sta, LCR3.sta, LCRn.sta									
	W	0x2006	0x0001	2	char(0 ~ 50)	Load the specified file in the usb directory of the flash drive. n value range: 0 ~ 50 Specify the file in the USB root directory in the same format as above.				

7.4 Examples of Writing Commands

7.4.1 Examples of LCR Scan Commands

Step		Command	Description
1	General Parameters	DISP:PAGE TSME	Go to the curve page.
		TRIG:SOUR SING	Set the trigger source to single trigger.
		FREQ 1000	Set the common frequency; the sweep frequency is also determined by the start and end points.
		VOLT 1	Set the test AC level.
		BIAS:VOLT 0	Set the bias voltage. If you need to add bias, you must issue the command BIAS:STAT ON before the test and the command BIAS:STAT OFF after the test.
2	LCR Parameters	TSSE:POINT 101	Set the number of points.
		TSSE:SMODE SEQ	Set the scan mode to sequential.
		TSSE:MODE FREQ	Set the scan object to frequency, i.e. horizontal coordinate.
		TSSE:FORM LIN	Set the point distribution mode to linear.
		TSSE:SWEEP 1e3, 1e6	Set the start and end points of the horizontal coordinate.
		TSSE:IMP Z, CS, LS, D	Set the result parameters for the 4 vertical coordinates.
3	Trigger Test	TRIG	Run a test.
		TRIG:STAT?	Query the test status; returns RUN 1 if there is a test running and RUN 0 is there is not.
4	Query Results	Read test results after the query reaches RUN 0	Query the test results, see the section on Query Curve Scanning Results, query the required data as needed (because of the large amount of data).
		FETC:TRACE:Y 1?	Query the results of all points of parameter 1.
		FETC:TRACE:Y 3?	Query all points of parameter 3.

8 Handler Interface Description

ST2840 series instruments provide users with a Handler interface, which is mainly used for the output of sorting results. When the automatic component sorting test system is used, this interface provides the communication signal with the system, as well as the sorting result output signal.

The BIN sorting and list sweep sorting of the bridge module uses the 57BR-4036L interface.

For the specific location of the interface, refer to the introduction of the rear panel given in Chapter 2. The Handler Interface design is flexible; upon using different operating procedures, all output signal states are defined according to the specific requirements.

8.1 BIN Sorting

The interface model provided by the BIN sorting instrument is 57BR-4036L, which provides /BIN1 ~ /BIN10 ten-BIN sorting and total PASS and FAIL signals.

8.1.1 Technology Description

8.1.1.1 Output Signal

Active low (default), open collector, optoelectronic isolation.

Table 8-1 Output Signals

Signal	Overview
/BIN1 ~ /BIN10 PASS, FAIL	Result Output
/INDEX	"Analog Measurement End" Signal
/EOM	"End of All Measurements" Signal
/ALARM	Provides an alert when a momentary power failure or processor interface board reset is detected.

8.1.1.2 Input Signal

Optoelectronic isolation.

Table 8-2 Input Signals

Signal	Overview
/KEY_LOCK	Key Lock (locks the front panel keyboard, including the touch screen)
/EXT_TRIG	External Trigger: pulse width $\geq 1 \mu\text{s}$

8.1.1.3 Signal Line Description

The Handler interface has 3 signals: comparison output, control output and control input. The following are the signal definitions of the Handler Interface when the BIN comparison function is used.

Comparison Output Signal:

- /BIN1 ~ /BIN10
- PASS
- FAIL

Control Output Signal:

- /INDEX (analog measurement end signal)
- /EOM (measurement end and comparison data valid signal)
- /ALARM (instrument power down signal)

Control Input Signal:

- /EXT.TRIG (external trigger signal)
- /Keylock

The interface diagram of the above pins is shown in Figure 8-1. See Table 8-3 for the signal assignment and brief description of the above pins. The timing diagram is shown in Figure 8-3.

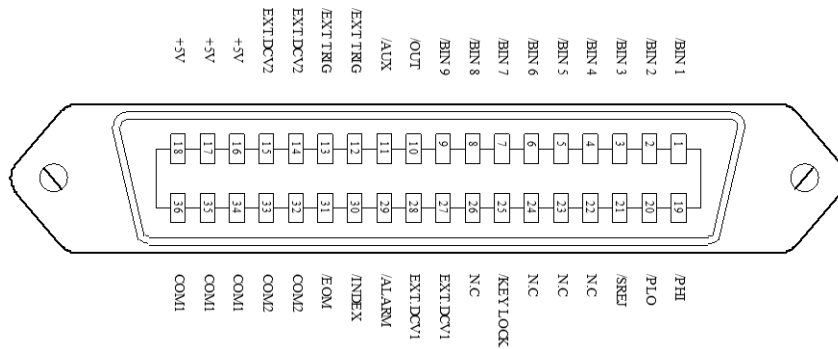

Figure 8-1 Interface Diagram

Note: Figure 8-1 is just the interface definition of the BIN sorting, and the definition of the list sweep sorting is different.

Table 8-3 Signal Distribution Table for the Pins Comparison Function

Pin	Signal	Signal Direction	Description
1	/BIN1	Output	BIN sorting result. All /BIN outputs are open collector outputs.
2	/BIN2		
3	/BIN3		
4	/BIN4		
5	/BIN5		
6	/BIN6		
7	/BIN7		
8	/BIN8		
9	/BIN9		
10	/BIN10		
11	Undefined	Output	Factory measurement signal, please do not connect.

12 13	/EXT.TRIG	Input	External Trigger: When the trigger mode is set to Single, your ST2840 instrument will be triggered by the positive-edge in this pin.
14 15	EXT.DCV2	Input	External DC Voltage 2: The DC provider pin for the optoelectronic coupling signal (/EXT_TRIG, /KeyLock, /ALARM, /INDEX, /EOM).
16 17 18	+5 V	Output	The Internal Power +5 V: It is not recommended to use the internal power. If you do use the internal power, please ensure that the current is lower than 0.3 A and that the signal line is far from the disturbance source.
19	/PASS	Output	As long as the measurement result is in any one of /BIN1 ~ /BIN10, the output will be /PASS (see Figure 10-2).
20	/FAIL	Output	If the measurement result is not in any one of /BIN1 ~ /BIN10, the output will be /FAIL (see Figure 10-2).
21 22 23 24	Undefined	Output	Factory measurement signal, please do not connect.
25	/KEY LOCK	Input	When this signal is effective, all the front panel function keys and touch screen of ST2840 are locked and no longer work.
27 28	EXT.DCV1	Input	The External DC Voltage 1: The pull-up DC power provider pin for optoelectronic coupling signal (/BIN ~ /BIN10, /PASS, /FAIL).
29	/ALARM	Output	Warning that the circuit has been interrupted.
30	/INDEX	Output	When the analog test is finished and the UNKNOWN terminal can be connected to another DUT, /INDEX is output. But the comparison signal is output until the /EOM signal.
31	/EOM	Output	End of Measurement: Once the test data and the comparison results are output, this signal is also output.
32 33	COM2	–	The reference ground for external power EXTV2.
34 35 36	COM1	–	The reference ground for external power EXTV1.

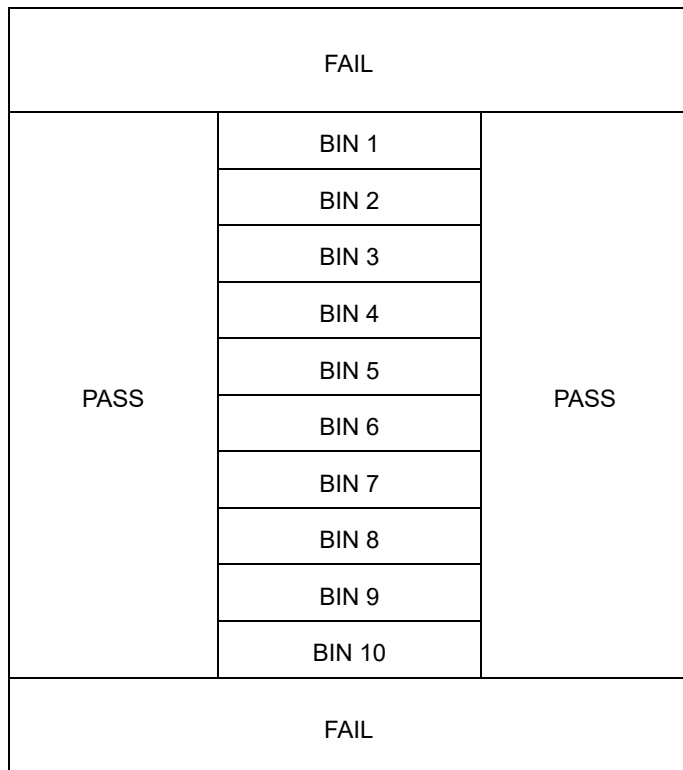

Figure 8-2 Example of the Distribution Area of the Comparison Function Signals /PASS and /FAIL

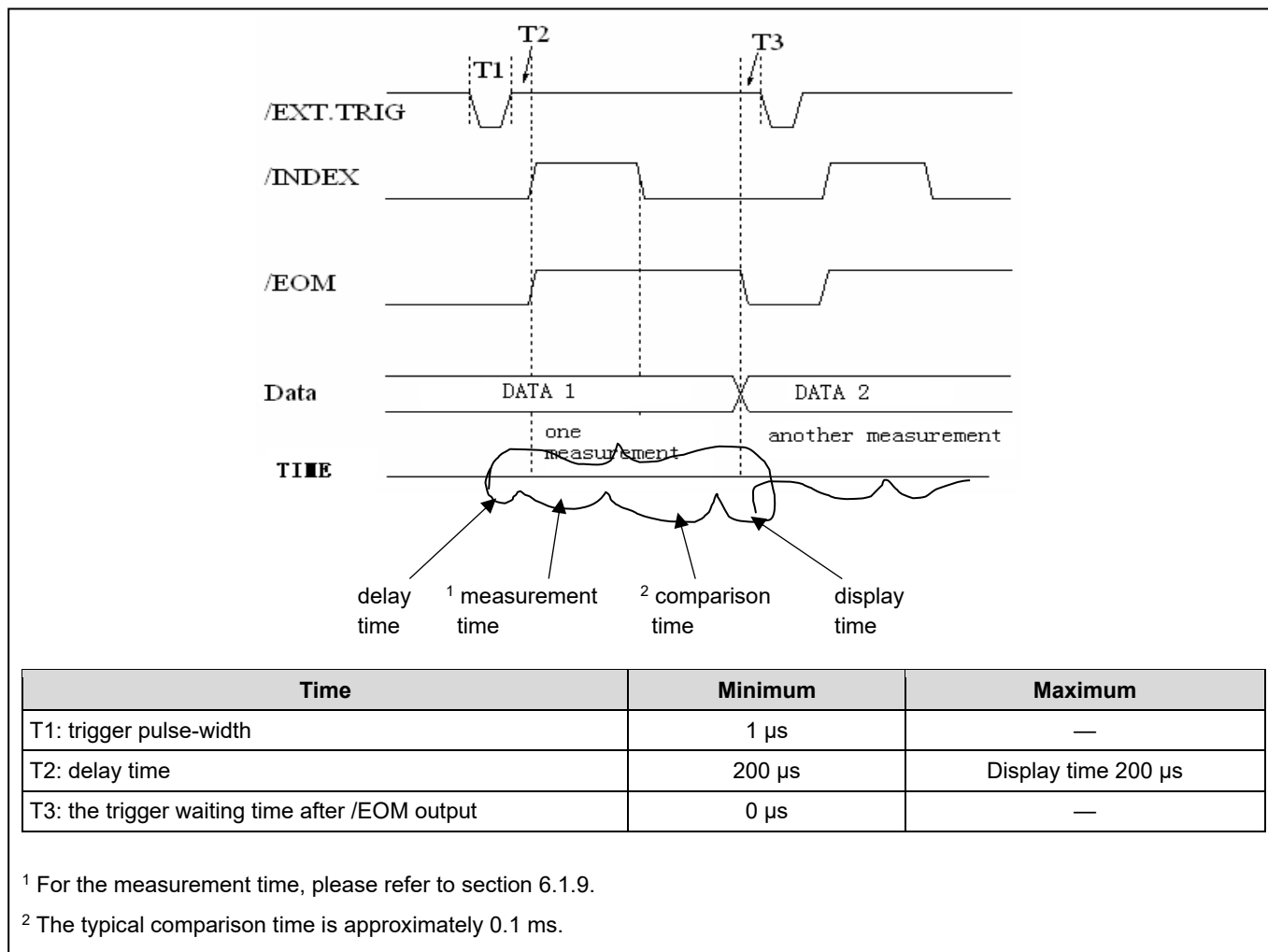

Figure 8-3 Timing Chart

8.1.2 Electrical Features

As it is shown above, the signal definition for the comparison and the list sweep comparison are different. But the electrical feature is same. So the description can be applied to BIN comparison and list sweep comparison.

8.1.2.1 DC Isolation Output Signal

Each DC output (pin 1 to 11, 19 to 24, and 29 to 31) is isolated via an open collector optocoupler output. The output voltage of each line is set by a pull-up resistor on the Handler Interface board. The pull-up resistor is connected with the internal supply voltage (+5 V) or with the external supply voltage (EXTV: +5 V ~ 24 V) by jumper.

The DC isolated output signal utilizes a dedicated electrical system which is independent of the control output signal. Therefore, the processor board has a common line for two separate circuits: COM1 and COM2.

The electrical characteristics of the DC isolated output are divided into two types (see Table 8-4). The output circuit configuration of the measurement result output signal is shown in Figure 8-5, and the output circuit configuration of the control output signal is shown in Figure 8-4.

Table 8-4 DC Isolation Output Electrical Features

Output Signal	Output Rated Voltage		Maximum Current	Reference Ground for the Circuit
	LOW	HIGH		
Comparison Signal: <ul style="list-style-type: none"> • /BIN1 ~ /BIN10 • /PASS • /FAIL 	≤ 0.5 V	+5 V ~ +24 V	6 mA	Internal Pull-Up Voltage: <ul style="list-style-type: none"> • ST2840 GND • EXTV1: COM1
Control Signal: <ul style="list-style-type: none"> • /INDEX • /EOM • /ALARM 				Internal Pull-Up Voltage: <ul style="list-style-type: none"> • ST2840 GND • EXTV2: COM2

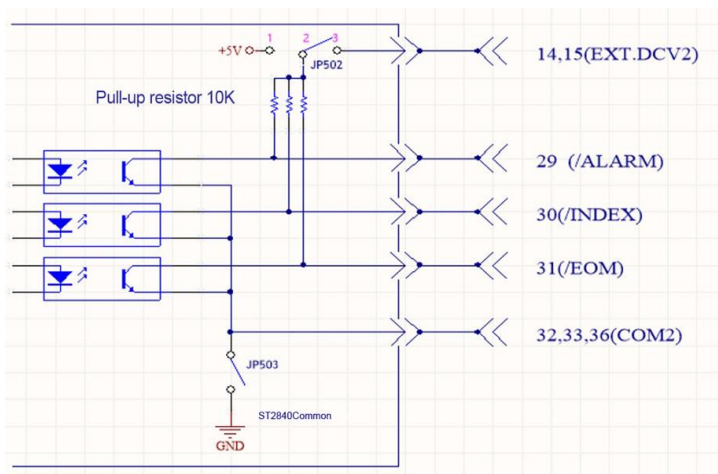

Figure 8-4 Control Signal Output Circuit

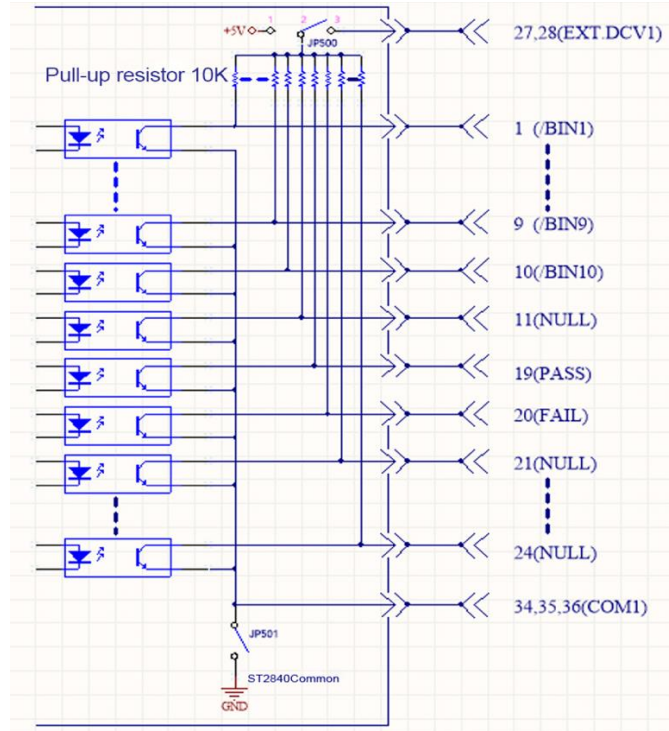

Figure 8-5 Comparison Result Signal Output Circuit

8.1.2.2 DC Isolation Input Signal

DC isolation input signals include the /EXT_TRIG and /KEY_LOCK signals.

The /EXT_TRIG signal (pin 12 and pin 13) is input to the LED cathode side of the optocoupler.

The instrument is triggered when the signal increases from LOW to HIGH. The optocoupler LED (anode side) can be driven by an internal pull-up voltage (+5 V) or an external voltage (EXT.DCV2).

The /KEY_LOCK signal (pin 25) is input to the optocoupler LED (on the cathode side). As long as this is low level, the keys on the front panel of the instrument will all be locked. The optocoupler LED (anode side) can be driven by internal voltage (+5 V) or external voltage (EXT.DCV2).

The input circuit configuration of the DC isolation input signal is shown in Figure 8-6.

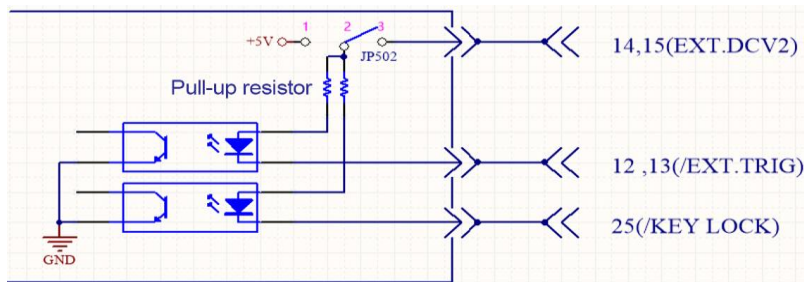

Figure 8-6 Input Signal Circuit Configuration

8.1.3 Handler Wiring Instructions of BIN Sorting

This section focuses on an example of the wiring between ST2840 and a typical PLC. The wiring example only introduces the wiring of two PLCs, that is, the PLC input circuit common anode and the PLC input circuit common cathode. For PLCs with other types of input circuits, please consult customer service for further assistance.

The PLC input circuit common anode means that the current flows in from the common terminal of the module and flows out from the input channel of the module, which is often referred to as the source wiring method.

The PLC input circuit common cathode means that the current flows in from the input channel of the module and flows out from the common terminal of the module, which is often referred to as the drain wiring method.

Figure 8-7 shows the PLC wiring diagram where the handler interface and input circuit are common anode when using BIN sorting, and Figure 8-8 shows the equivalent PLC wiring diagram where the handler interface and input circuit are common cathode.

The factory default of ST2840 series instruments is external power supply. That is, pins 2 and 3 of JP500 are short-circuited, pins 2 and 3 of JP502 are short-circuited, JP501 is open, and JP503 is open. Therefore, be sure to connect the power supply to the external power supply pin when using it.

If you need to use the internal power supply of the instrument, you need to change the jumper mode of JP500 ~ JP503; please consult customer service for further information.

Warning!	
	<p>16, 17, and 18 are the 5 V power supply inside the instrument and cannot be connected to any external power supply, otherwise the instrument will get damaged.</p> <p>Considering the anti-interference ability of the instrument, it is recommended to provide and use an external power supply as the pull-up power supply for the optocoupler.</p>

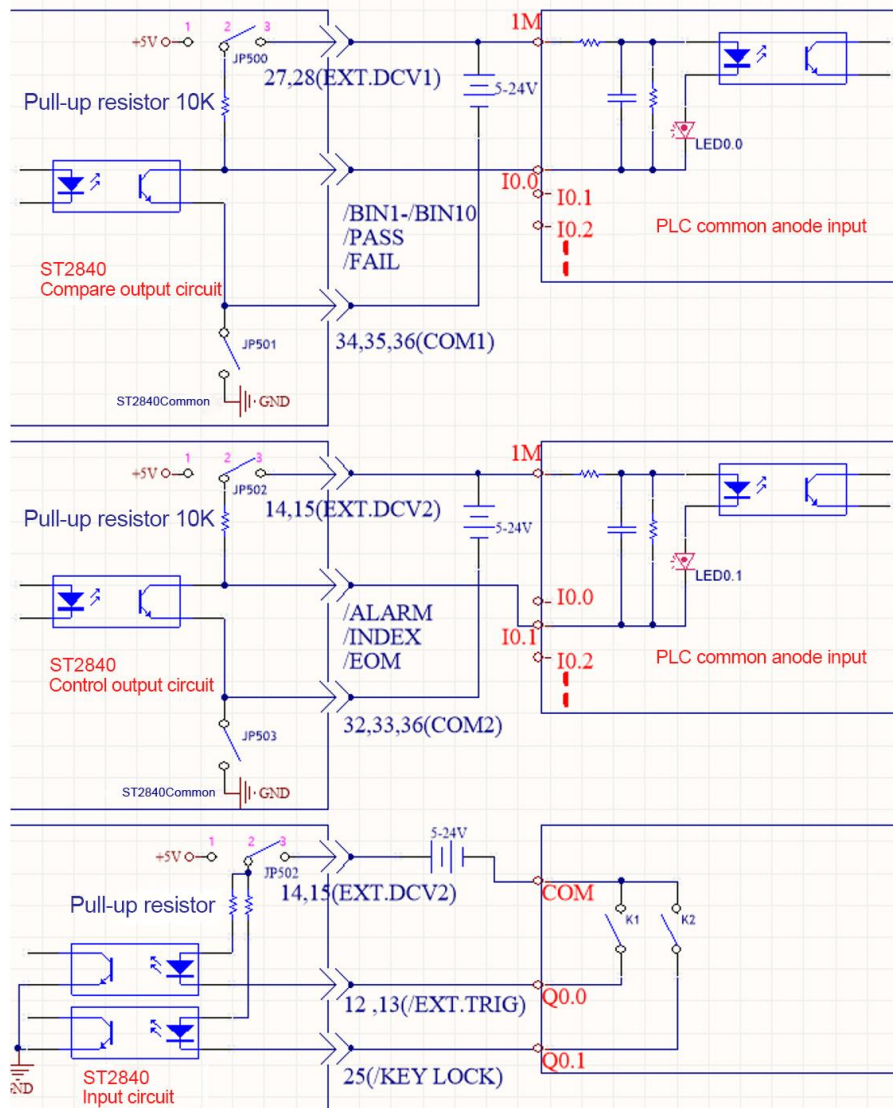

Figure 8-7 PLC Wiring Diagram Where Handler Interface and Input Circuit are Common Anode

EXT.DCV1 and EXT.DCV2 can use the same set of external power supplies, or they can use different sets of power supplies. The corresponding low end of EXT.DCV1 is COM1, and the corresponding low end of EXT.DCV2 is COM2. The input circuit and the control output circuit use the same group of power supplies, namely EXT.DCV2.

The wiring method provided in this figure is a typical connection method, and it needs to be flexibly applied according to the actual situation in practical application.

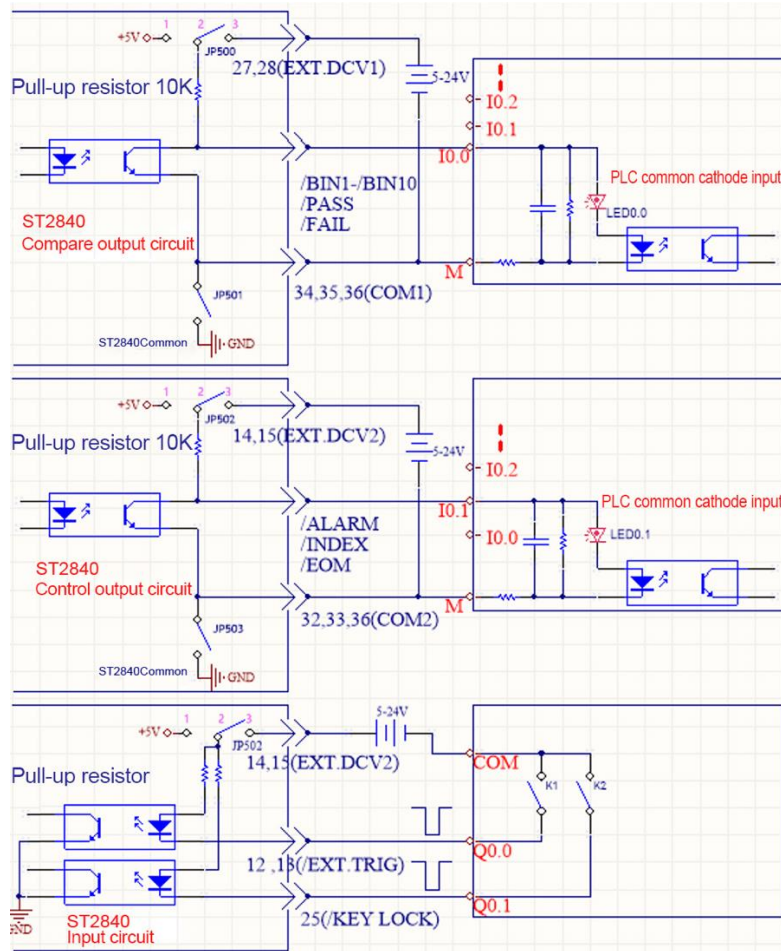

Figure 8-8 PLC Wiring Diagram Where Handler Interface and Input Circuit are Common Cathode

8.1.4 Using Operations

After the Handler Interface is correctly wired to the PLC, set the limit list to use the comparison function. Then set the Handler Interface accordingly so that it can output/input signal.

8.1.4.1 Comparison Function Setting Procedure

The following operation steps are the steps of the comparison function using the Handler Interface (only for the functions of the automatic component analyzer).

- 1) Press the [SETUP] key, select <Limit Setup> in the menu on the right side of the display, and enter the limit setup page.
- 2) Move the cursor to "Comp", select ON in the menu area on the right side of the screen, and the comparator function will be enabled.
- 3) Move the cursor to "Count", then select ON in the menu area on the right side of the screen, and the counting function will be enabled.
- 4) Move the cursor to "Mode", then select "Tolerance" or "Continuous" in the menu area on the right side of the screen.

- 5) Set the BIN sorting deviation type, reference value, BIN limit and related options on the <Limit Setup> page.
- 6) Press [DISP] to enter the <Meas Display> page, and enter the corresponding page to measure the DUT.

Note: The ON/OFF of the comparison function and the ON/OFF of the counting function can also be set in the <Meas Display> page.

8.2 List Sweep

When using the list sweep sorting, the interface model provided by the instrument is 57BR-4036L (the same interface as the BIN sorting), and provides /FAIL1 ~ /FAIL10 and the total /PASS and /FAIL signals.

8.2.1 List Sweep Sorting Logic

A maximum of 4 parameters can be set for each sweep point. The upper and lower limits of the corresponding parameter settings indicate that they participate in the sorting. If the upper and lower limits are not set, they are not considered in the sorting.

All the parameters considered in the sorting among the 4 parameters are qualified, indicating that the sweep point is qualified. As long as there is one unqualified sweep point, the sweep point is judged to be unqualified. In the list sweep display interface, the P/F column at the end of each sweep point will display PASS or FAIL, and the sweep points without upper and lower limits will be displayed at the corresponding P/F.

Sweep points 1 ~ 10 correspond to /BIN1 ~ /BIN10 in sequence, and all are active low. The sorting results of sweep point 11 and subsequent sweep points do not have separate sorting signals. If all the sweep points with upper and lower limits are qualified, a total PASS signal will be output, and if one of the sweep points with upper and lower limits is set unqualified, a FAIL signal will be output. Sweep points that do not have upper and lower limits set do not participate in the sorting.

8.2.2 Technical Description

8.2.2.1 List Sweep Output Signal

Active low, open collector, optoelectronic isolation

Table 8-5 Output Signals

Signal	Overview
/BIN1 ~ /BIN10 PASS, FAIL	Result Output
/INDEX	"Analog Measurement End" Signal
/EOM	"End of All Measurements" Signal
/ALARM	Provides an alert when a momentary power failure or processor interface board reset is detected.

8.2.2.2 List Sweep Input Signal

The input signal is the same as for BIN sorting (see section 8.1.1.2).

8.2.2.3 Signal Line Definition

The list sweep sorting Handler Interface uses three signals: compare output, control input and control output. The following are the signal definitions of the Handler Interface when the list sweep sorting function is used.

The signal definition of the list sweep comparison function is different from that of the BIN comparison function. Its definition is as follows:

Comparison Output Signal:

- /FAIL1 ~ /FAIL10
- PASS
- FAIL

The /FAIL1 ~ /FAIL10 signal indicates the successful pass or the out-of-tolerance judgment of each sweep point, see Figure 10-9. The /PASS and /FAIL signals are indicated as total judgment signals. These signals will be output when a sweep measurement is completed.

Control Output Signal:

- /INDEX (analog measurement completion signal)
- /EOM (measurement end and comparison data valid signal)
- /ALARM (instrument power down signal)

SEQ Sweep Mode: The /INDEX signal registers after the analog measurement of the last sweep point is completed. The /EOM signal registers after each step of measurement and comparison is completed.

STEP Sweep Mode: The /INDEX signal registers after the analog measurement of each sweep point is completed. The /EOM signal registers after each step of measurement and comparison is completed.

The timing diagram is shown in Figure 8-10.

Control Input Signal: /EXT.TRIG (external trigger signal)

The interface diagram of the above pins is shown in Figure 8-1.

See Table 8-6 for the signal assignment and brief description of the above pins.

Table 8-6 Pin Distribution Table of the List Sweep Sorting Function

Pin	Signal	Signal Direction	Description
1	/FAIL1	Output	Out of the limit of sweep point 1
2	/FAIL2		Out of the limit of sweep point 2
3	/FAIL3		Out of the limit of sweep point 3
4	/FAIL4		Out of the limit of sweep point 4
5	/FAIL5		Out of the limit of sweep point 5
6	/FAIL6		Out of the limit of sweep point 6
7	/FAIL7		Out of the limit of sweep point 7
8	/FAIL8		Out of the limit of sweep point 8
9	/FAIL9		Out of the limit of sweep point 9
10	/FAIL10		Out of the limit of sweep point 10

11	Undefined	Output	Factory test, please do not use.
19	/PASS	Output	All points in the measurement result are passed, it is /PASS.
20	/FAIL	Output	As long as one point in the measurement result fails, it is /FAIL.
30	/INDEX	Output	<p>SEQ: The /INDEX signal registers after the analog measurement of the last sweep point is completed, and the UNKNOWN test terminal of the ST2840 can be connected to the next device under test (DUT). However, the comparison result signal does not register until the /EOM signal.</p> <p>STEP: The /INDEX signal is asserted valid after the analog measurement of each sweep point is completed. However, the comparison result signal does not register until the /EOM signal.</p>
31	/EOM	Output	<p>End of Measurement</p> <p>Sequential Sweep Mode (SEQ): The /EOM signal registers after the entire list sweep measurement is completed and all comparisons are done.</p> <p>Single-Step Sweep Mode (STEP): The /EOM signal registers after each sweep point measurement is completed and all comparisons are done. The comparison result signal remains until the /EOM signal of the final sweep point.</p>
Other	–	–	The definition is the same as that of the comparison (see Table 8-3).

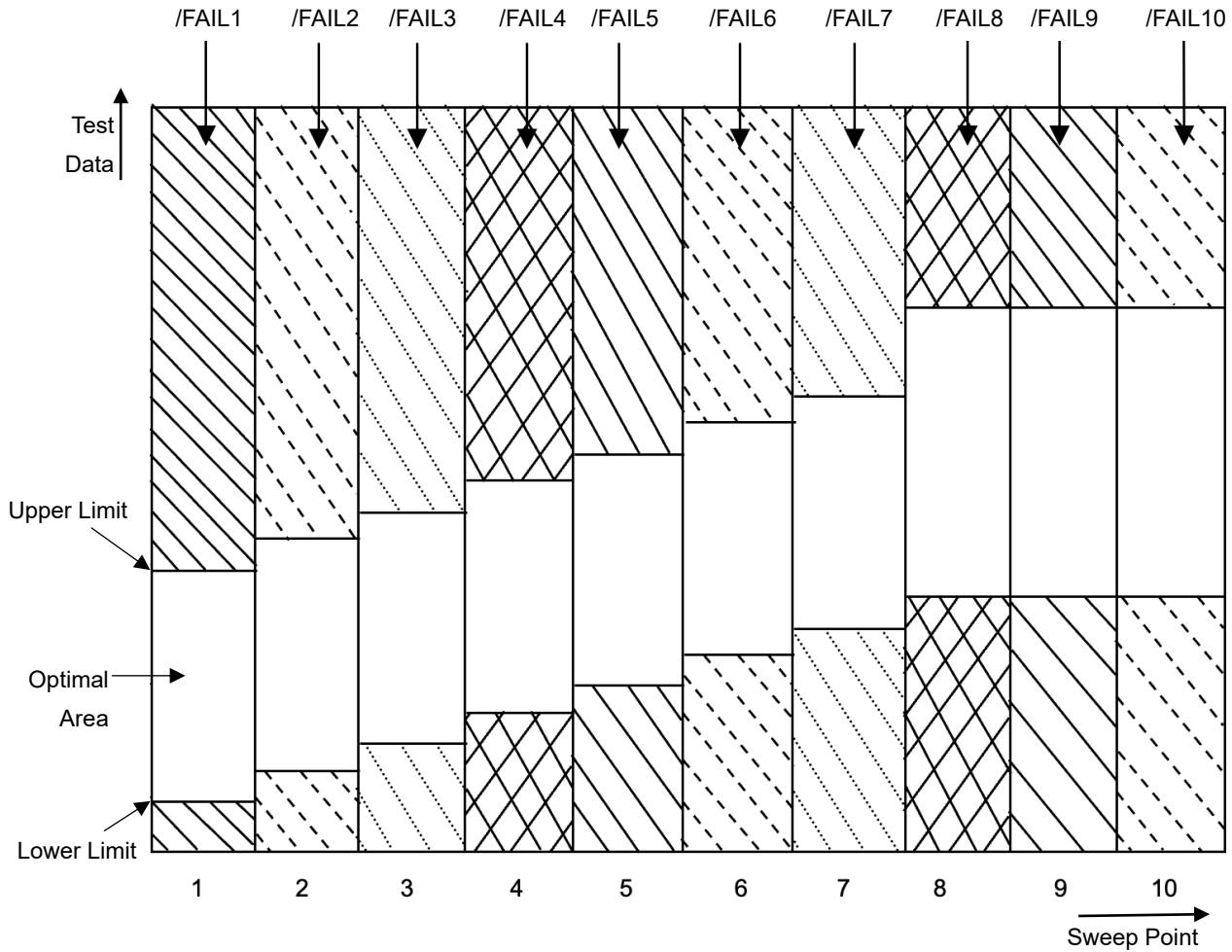

Figure 8-9 Signal Area of the List Sweep Comparison

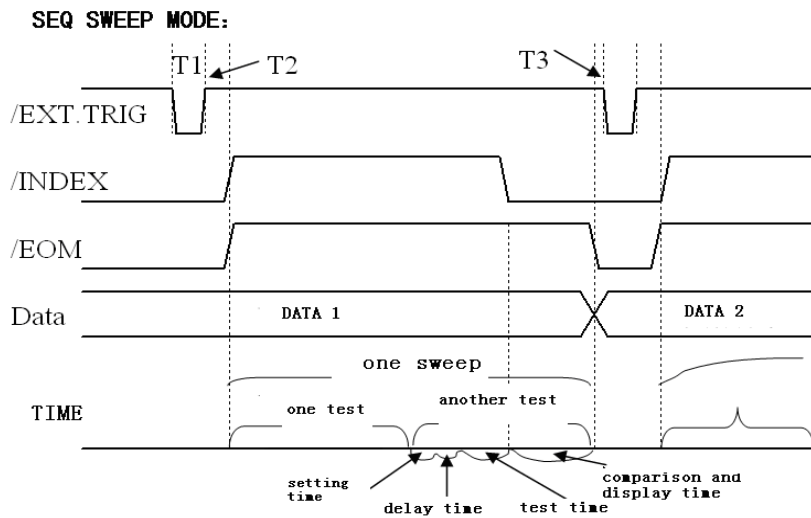

Figure 8-10 Timing Chart (Sequential Mode)

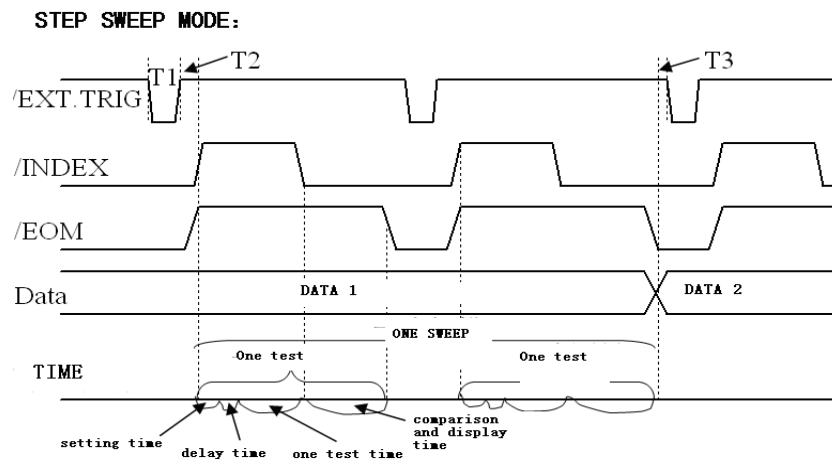

Figure 8-11 Timing Chart (Single-Step Mode)

Note:

- The setting time includes the correction ON/OFF time.
- The comparison and display time is 4.5 ms approximately.

8.2.3 Electrical Features

The meanings of some signals in the list sweep comparison function and the BIN sorting function are different. However, the electrical characteristics of these signals are the same in both operations, so refer to 8.1.2 for a description of the electrical characteristics of the list sweep sorting function.

8.2.4 Wiring Instructions

The list sweep and BIN sorting share the same Handler Interface in the hardware circuit, and the electrical properties corresponding to the same pin numbers are exactly the same. It is essentially the same as the PLC wiring diagram. Therefore, for the wiring diagrams please refer to 8.1.3.

8.2.5 Using the List Sweep Comparison

Using the Handler Interface, set the high and low limits in the list sweep to use the comparison function. Then set the Handler Interface so that it can OUTPUT/INPUT signal. The following are the steps to take in order to use the Handler Interface list sweep comparison function.

8.2.5.1 List Sweep Compare Function Setting Steps

- 1) Press the [SETUP] button and click [List Setup] in the menu on the right side of the screen to enter the <List Sweep Setup> page.
- 2) In the <List Sweep Setup> menu, set the sweep method, sweep frequency point, reference value, upper and lower limits, etc.
- 3) Press [DISP] to enter the <List Display> page. For a full description of this page, please refer to the section on the [DISP] menu key.