

ST2821

Portable LCR Meter

OPERATION MANUAL

English

September 2007

1st Edition Rev 1.0.0

All rights reserved.

Contents

<i>Contents</i>	2
How to Contact Us	3
Incoming Inspection	4
Notes on Use	5
Warranty:	6
<i>Chapter 1 Overview</i>	7
1.1 Introduction.....	7
1.2 Main Functions	7
1.3 Specifications.....	9
1.4 Environment Requirements.....	12
<i>Chapter 2 Panel Illustration</i>	13
2.1 LCD Display Illustration	13
2.2 Keyboard Illustration	15
<i>Chapter 3 Operation</i>	17
3.1 Power on	17
3.2 How to operate	18
3.2.1 First Key Functions	18
3.2.2 Second Key Functions:	20
3.3 Battery Replacement	30
3.4 Clearing Instruction	31
<i>Appendix</i>	32

How to Contact Us

SOURCETRONIC
Georg-Groening-Strasse 47
D-28209 Bremen
Germany
Fon: +49 421 277 9999
Fax: +49 421 277 9998
info@sourcetric.com
www.sourcetric.com

Incoming Inspection

Inspect the shipping container for damage. The contents of the shipment should be listed as follows. If the contents are incomplete, if there is damage or defect, please contact our company or your nearest Sales and Service Office.

Accessories

ST26028 DC Power Adapter	1
ST26027 4 terminal Kelvin test clip leads	1
1604A 9V battery	1
User Manual	1

Options

ST26029 SMD component test fixture

Notes on Use

- This meter is only for indoor use.
- Turn off the ST2821 while switching the power supply between battery and DC adapter or replacing the battery.
- Although internal circuit protection is provided, DC voltage or current may damage ST2821. Before you measure a capacitor, be sure the capacitor is fully discharged.
- Take out the battery when the meter is not in use for more than 3 months.
- A single standard 9V battery can be used for the power supply. ST2821 will not work normally when battery voltage is less than 6V.
- The 12V AC to DC adaptor is recommended to be used for ST2821 power supply.
- Perform Open and Short corrections for accurate measurement especially when test fixture is changed.
- The functions locked with password are not accessible by users.

Warranty:

This instrument product is warranted against defects in material and workmanship for a period of one year from the date of shipment. During the warranty period, Our company will, at its option, either repair or replace products which prove to be defective. For warranty service or repair, this product must be returned to a service facility designated by our company.

Warranty limitation

The foregoing warranty shall not apply to defects resulting from improper or inadequate maintenance by Buyer, Buyer-supplied software or interfacing, unauthorized modification or misuse, or improper site preparation or maintenance.

Chapter 1 Overview

Thank you for purchasing our product. To get the maximum performance from the instrument, please read this manual first, and keep this manual at hand.

1.1 Introduction

ST2821 is a microprocessor-controlled portable meter with low power consumption. It can measure six basic parameters, they are inductance L, capacitance C, resistance R, impedance $|Z|$, dissipation factor D and quality factor Q. ST2821 can fulfill the measurement needs of various component manufacturers and maintenance technicians.

1.2 Main Functions

1. Test Parameter

L-Q, C-D, R-Q and Z-Q.

2. Correction

OPEN: multi-frequency correction of open circuit;

SHORT: multi-frequency correction of short circuit.

3. Display Mode

Direct — direct measurement value;

Δ — absolute deviation;

$\Delta\%$ — percent deviation.

4. Range Hold

When measuring a large number of components with the same nominal value, this function can effectively

improve the measuring rate.

5. Comparator Function

Built-in 4 Bins comparator: NG, P1, P2 and P3.

6. Equivalent Circuit Mode

Both parallel and series equivalent circuit modes can be obtained.

7. Data Hold

This function can be used to freeze the current display value.

8. Alarm Mode

NG, P1, P2, P3 and OFF modes can be selected.

ST2821 OPERATION MANUAL

1.3 Specifications

Parameter	L-Q, C-D, R-Q and Z-Q		
Frequency	100 Hz, 120 Hz, 1 kHz and 10 kHz		
Accuracy	Basic Accuracy: 0.3%		
Display	5 digits display for both primary and secondary parameters		
Measurement Range	L	100 Hz, 120 Hz	1 μ H - 9999 H
		1 kHz, 10 kHz	0.01 μ H - 999.9 H
	C	100 Hz, 120Hz	1 pF - 9999 μ F
		1kHz, 10 kHz	0.01 pF - 999.9 μ F
	R, Z	0.0001 Ω - 999.9 M Ω	
	D, Q	0.0001 - 9999	
$\Delta\%$	0.0001% - 9999%		
Test Level (Range Auto and Open Circuit)	120Hz 1kHz	0.3 Vrms (1 \pm 15%)	
	100Hz 10 kHz	0.42 Vrms (1 \pm 15%)	
Ranging Mode	Auto and Hold		
Equivalent Circuit	Parallel and Series		
Display	Direct, Δ ABS and $\Delta\%$		
Correction	Open and Short Zeroing		
Rate	Approx. 3 meas/sec		
Terminals	5 terminals		

ST2821 OPERATION MANUAL

Comparator	4 Bins: NG, P1, P2 and P3		
Limit Setup Range	$\Delta\%$	-9999% - 99999%	
	Nominal	L	0.0001 μH - 99999 H
		C	0.0001 μF - 99999 μF
		R	0.0001 Ω - 99999 $\text{M}\Omega$
Z		0.0001 Ω - 99999 $\text{M}\Omega$	
Alarm Mode	NG, P1, P2, P3 and OFF		
Power Supply	GPI7R8H rechargeable battery or DC12V(150 mA) adapter		
Low Battery Indication	Approx. 6V		
Power Consumption	Normal: Approx. 25 mA Auto power-off: Approx. 500 nA		
Auto Power Off time	Approx. 5 minutes		
Weight	Approx. 400 g		
Dimensions	200mm(L) \times 95mm(W) \times 40mm(D)		

Table 1-1 Specifications

 **Note:**

Primary parameter accuracy(A_e)

$$C: A_e = 0.3\% (1 + C_x/C_{\max} + C_{\min}/C_x)$$

$$L: A_e = 0.3\% (1 + L_x/L_{\max} + L_{\min}/L_x)$$

$$Z: A_e = 0.3\% (1 + Z_x/Z_{\max} + Z_{\min}/Z_x)$$

$$R: A_e = 0.3\% (1 + R_x/R_{\max} + R_{\min}/R_x)$$

Max and Min values are as follows:

Parameter	Range Auto
C_{\max}	80 μ F/f
C_{\min}	150pF/f
L_{\max}	159H/f
L_{\min}	0.32mH/f
Z_{\max}	1M Ω
Z_{\min}	1.59 Ω

Here: $Z_{\max} = R_{\max}$; $Z_{\min} = R_{\min}$, Frequency unit: kHz.

Secondary parameter accuracy

$$D_e = A_e/3 \quad \text{when } D_x \leq 0.1$$

$$D_e = A_e(1+D_x)/3 \quad \text{when } D_x > 0.1$$

$$Q_e = \pm \frac{Q_x \times D_e}{1 \mp Q_x \times D_e} \quad \text{when } Q_x \cdot D_e < 1$$

1.4 Environment Requirements

1. Please do not operate ST2821 under the following environment conditions, as any of them will directly affect measuring precision or damage the meter:
 - *Please do not operate the instrument in places where is dusty, vibrant, under direct sunlight, or where there is corrosive air.*
 - *Although ST2821 has been specially designed for reducing the noise caused by AC power, the environment with low noise is still recommended. If this can not be arranged, please make sure to use power filter for the AC-DC adaptor.*
2. The ST2821 must be operated under the following environment conditions:
Temperature: 0°C - 40°C,
Humidity: ≤ 90% RH at 40°C.
3. Storage Temperature: -25°C - 50°C.

Chapter 2 Panel Illustration

2.1 LCD Display Illustration

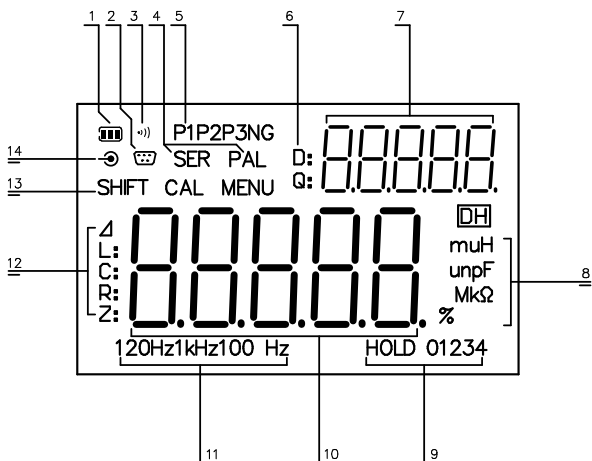

Figure 2-1 LCD Display

No.	Description	No.	Description
1	Battery Power Indicator	8	Unit Indicator
2	Remote Indicator	9	Ranging Mode Indicator
3	Beeper Indicator	10	Primary Parameter Display
4	Series/Parallel Indicator	11	Frequency Indicator
5	Comparator Indicator	12	Primary Parameter Indicator
6	Secondary Parameter Indicator	13	2 nd Function Indicator
7	Secondary Parameter Display	14	DC Adaptor Power Supply Indicator

Table 2-1 LCD Description

Others:**DH:** Data hold indicator**CAL:** Correction function indicator**MENU:** Menu operation indicator

2.2 Keyboard Illustration

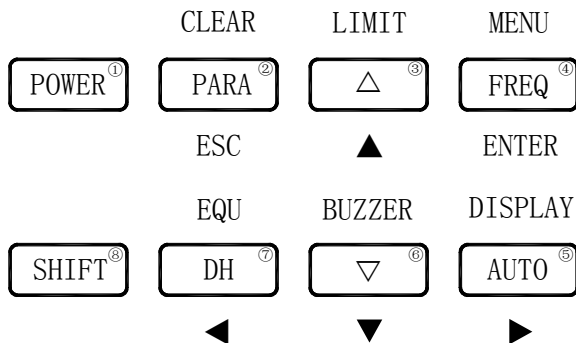

Figure 2-2 Keyboard

 Convention:

Key Function Conventions

1st function: 

2nd function: 

3rd function: 









No.	Key	Function	SHIFT+ Key	Function
1	POWER	Power On/Off		
2	PARA	Parameter Selection	CLEAR	Correction key
3		Range Up	LIMIT	Sorting Limit Setup
4	FREQ	Frequency Selection	MENU	Auxiliary Menu
5	AUTO	Range Auto Selection	DISPLAY	Display Mode Selection
6		Range Down	BUZZER	Alarm Mode Setup
7	DH	Data Hold	EQU	Equivalent Circuit
8	SHIFT	2 nd Function		

Table 2-2 Key Description

The 3rd Functions:

, , , ,  and  are valid during Menu setup and Data input operations.

Chapter 3 Operation

3.1 Power on

1. Press **POWER** key to turn on ST2821.
2. The operation system version will be displayed.
3. At last the instrument enters the measurement state.

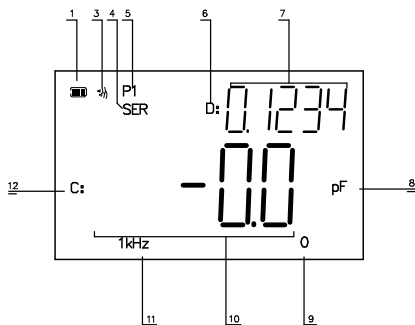

Figure 4-1 Measurement Display

Measurement display description:

- | | |
|-----------------------|------------------------|
| 1. Battery Supply | 3. Beeper ON |
| 4. Series Circuit | 5. Sorting Result: P1 |
| 6. Parameter D | 7. Secondary parameter |
| 8. Unit | 9. Range 0 (Auto) |
| 10. Primary parameter | 11. Frequency: 1 kHz |
| 12. Parameter C | |

3.2 How to operate

3.2.1 First Key Functions

1. Parameter Setup:

Press **PARA** key to select the following measurement parameter combinations: L-Q, C-D, R-Q and Z-Q.

Units Description:

L	μH	mH	H
C	pF	nF	μF
R/ Z	Ω	k Ω	M Ω

Table 4-1 Units

|Z| is the absolute value of impedance. Measurement value of L, C or R may be positive or negative. Negative capacitance value means that the device under test is actually an inductor; also negative inductance value means that the device under test is actually a capacitor. In theory R should be positive constantly, under some condition, R may be negative due to over zero correction. Please carry out correct zero correction.

The maximum number of display digits is 5, but 5-digit is not always available and 4-digit is displayed sometimes.

The conversion is described in the following description:

From 4-digit to 5-digit:

When the first 2 digit of current value is less than 18.

From 5-digit to 4-digit:

When the first 2 digit of current value is more than 20.

2. Frequency Setup:

Use **FREQ** key to select the following test frequencies in turn: 100 Hz, 120 Hz, 1 kHz and 10 kHz.

ST2821 OPERATION MANUAL

3. Range Setup:

△, ▽ and AUTO keys are used to set the measurement range. AUTO key toggles ranging mode between “Auto” and “Hold”. △ and ▽ keys are used to increase or decrease the measurement range, if the current ranging mode is “Auto”, then the ranging mode is changed to “Hold” at the same time.



Note:

When ranging mode is set to HOLD, the measurement range is fixed at current range. Overload symbol “-----” will be displayed if the impedance under test exceeds the current effective measurement range or display range.

Range No.	Range Resistor	Range Up	Range Down
0	100kΩ	↑ 20kΩ	↓ 18kΩ
1	10kΩ	↑ 2kΩ	↓ 1.8kΩ
2	1kΩ	↑ 200Ω	↓ 180Ω
3	100Ω	↑ 20Ω	↓ 18Ω
4	20Ω	↑	↓

Table 4-2 Ranges

 **Note:**

How to calculate the measurement range

Example: Assume capacitance $C=210\text{pF}$, dissipation $D=0.0010$ and test frequency $f=1\text{ kHz}$.

Solution:

$$Z_x = R_x + \frac{1}{j2\pi f C_x}$$

$$|Z_x| \approx \frac{1}{2\pi f C_x} = \frac{1}{2 \times 3.1416 \times 1000 \times 210 \times 10^{-9}} \approx 757.9\Omega$$

From the Table 4-2, we can get the correct measurement range is No. 2.

4. Data Hold

Press **[DH]** key to freeze the display, press **[DH]** key again to release.

3.2.2 Second Key Functions:

1. Correction Function

- Press **[Shift]** key to select the second function, “SHIFT” will be lighted on the screen.
- Press **[CLEAR]** key to enter the correction function, the following information will be displayed on the screen.

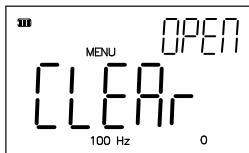



Figure 4-2 Correction Display

- Clear (Clear) is displayed in the primary parameter display area, Open (OPEN), Short (Short) or Quit (Quit) will be displayed in the secondary parameter display area.



Note:

Open (OPEN), Short (Short) and Quit (Quit) are selected and displayed automatically by the meter according to the impedance value of the device under test.

- Press  key to cancel the correction operation and return to the measurement state. Press  key to start the correction measurement.
- When correction measurement is finished, PASS or FAIL will be displayed on the screen, see Figure 4-3

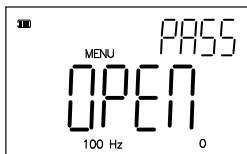



Figure 4-3 Open correction Passed

- Press  key to abort the current correction data measurement and return to the measurement. The previous correction data will still be stored.



Note:

1. The correction function must be used for accurate measurement. The correction function can eliminate the stray admittance

ST2821 OPERATION MANUAL

(capacitance, and inductance) and the residual impedance (resistance and reactance) induced by test fixture, test leads and instrument itself. Perform the correction operation again if the measurement conditions are changed such as test fixture and environment temperature.

2. It is recommended to perform the open and short correction at the same time.
3. During short correction period, FAIL (FAIL) will be displayed in the secondary parameter display area when short correction is failed. Make sure that the measurement contacts are shorted reliably and perform the short correction again.
4. ST2821 measures the correction data at all frequency points and all measurement ranges. The correction data is stored in the non-volatile memory. So you don't have to perform the correction again, if the test conditions are not changed.
5. Open and short corrections are automatically selected by the instrument according to the impedance value under test. If there is a component in the fixture or if there is error with the instrument, Quit (Quit) will be displayed in the secondary parameter display area.

2. Equivalent Circuit

- Press **Shift** key to select the second function, "SHIFT" will be lighted on the screen.
- Press **EQU** key to select the Series or Parallel circuit mode. (Refer to Figure4-1)



Note:

1. The actual C, R and L are not the ideal pure C, R and L. Normally an actual component can be regarded as the combination of an ideal resistor and an ideal reactor in series or parallel circuit mode.
2. ST2821 can convert between the two different equivalent circuit modes using the following equations. The measurement values of the two different circuit modes maybe different under different

quality factor Q (or dissipation factor D).

Capacitance C_p : from parallel to series

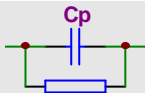

Circuit Mode:

Dissipation:
$$D = \frac{1}{2\pi f C_p R_p} = \frac{1}{Q}$$

Series:
$$C_s = (1 + D^2) C_p$$

$$R_s = R_p D^2 / (1 + D^2)$$

Capacitance C_s : from series to parallel

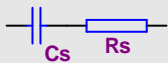

Circuit Mode:

Dissipation:
$$D = 2\pi f R_s C_s = \frac{1}{Q}$$

Parallel:
$$C_p = 1 / (1 + D^2) C_s$$

$$R_p = R_s (1 + D^2) / D^2$$

Inductance L_p : from parallel to series

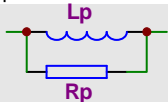

Circuit Mode:

Dissipation:
$$D = \frac{2\pi f L_p}{R_p} = \frac{1}{Q}$$

Series:
$$L_s = 1 / (1 + D^2) L_p$$

$$R_s = R_p D^2 / (1 + D^2)$$

Inductance Ls: from series to parallel

A circuit diagram showing an inductor labeled L_p in series with a resistor labeled R_p . The inductor is represented by a blue wavy line, and the resistor is represented by a blue rectangle.

Circuit Mode:

Dissipation:
$$D = \frac{R_s}{2\pi f L_s} = \frac{1}{Q}$$

Parallel:
$$L_p = (1 + D^2)L_s$$

$$R_p = R_s(1 + D^2)/D^2$$

Here parameter with subscript s means the series mode, parameter with subscript p means the parallel mode.

- From the above equations, we can conclude that the conversion between series and parallel is determined by D^2 or Q^2 ($Q=1/D$). The value of D^2 or Q^2 directly determined the parameter values in different circuit mode.

Example:

Three capacitors have the same series capacitance: $C_s=0.1\mu\text{F}$, but their dissipations are different with each other: $D_1=0.0100$, $D_2=0.1000$, $D_3=1.0000$. According to the above equation, we can get their capacitance in parallel mode:

$$C_{p1} = 0.09999 \mu\text{F}$$

$$C_{p2} = 0.09901 \mu\text{F}$$

$$C_{p3} = 0.05000 \mu\text{F}$$

We can find that C_s is almost the same with C_p when D is very small ($D < 0.01$), but when D is more than 0.01, C_p and C_s are different obviously. For example: When $D = 0.1$, the difference is 1%, but when $D = 1$, the difference is almost 50%.

3. Alarm Setup

- Press **Shift** key to select the second function, "SHIFT" will be lighted on the screen.
- Press **BUZZER**, the following information will be

displayed on the LCD screen:

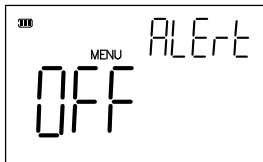







Figure 4-4 Alarm Setup

- Use  and  keys to select following alert modes in turn.
 - OFF Alert off
 - P1 P1 alert mode
 - P2 P2 alert mode
 - P3 P3 alert mode
 - Ng NG alert mode
- Press  to save the alert setup and return to the measurement state.
- press  to abort the alert setup without change.

4. Display Mode

- Press  key to select the second function, “SHIFT” will be lighted on the screen.
- Press **DISPLAY** key to select the display mode: Direct, Absolute deviation (Δ) , Percent deviation ($\Delta\%$) .



Note:

1. Absolute deviation (Δ) display mode

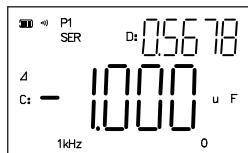

Figure 4-5 Absolute deviation (Δ) display mode

$$\Delta = X_x - X_{std}$$

Where X_x is the measurement value, X_{std} is the standard value.

2. Percent deviation ($\Delta\%$) display mode

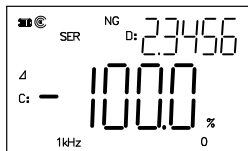

Figure 4-6 Percent deviation ($\Delta\%$) display mode.

$$\Delta\% = \frac{X_x - X_{std}}{X_{std}} \cdot 100\%$$

5. Sorting Setup





Key Convention:

Key	Main Menu	Data Input
	Select the former item	Select the left digit
	Select the next item	Select the right digit
	Select parameter for StD setup	Increase the digit, move the point left and set the unit
	Select parameter for StD setup	Decrease the digit, move the point right and set the unit
	Enter the sub menu	Confirm the data input, and return to the main menu
	Return to the measurement state	Return to the main menu

Table 4-4 Key convention in sorting setup

- Press key to select the second function, “SHIFT” will be lighted on the screen.
- Press **LIMIT** to enter the sorting setup, P1~ will be flashing on the screen, and the value of P1~ is also displayed.
- Use , to select the following sorting parameters:
 - P1_: Low limit of P1
 - P1~: High limit of P1
 - P2_: Low limit of P2
 - P2~: High limit of P2
 - P3_: Low limit of P3
 - P3~: High limit of P3
 - Q_: Low limit of Q
 - D~: High limit of D
 - StD: Standard value

- Press  key to abort the sorting setup and return to the measurement state.
- Press  key to select a parameter and enter the data input operation.

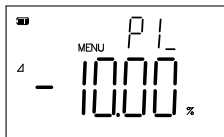







Figure 4-7 Sorting Limit Setup

- Use ,  keys to select a digit or the point.
- Use ,  keys to set the numeric value.
- Press  to return to the main menu.
- Press  to confirm and save the numeric data.
- Select parameter STD to set the standard Value.

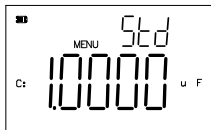







Figure 4-8 Standard Value Setup

- Use ,  keys to select a digit, the point or the unit.
- Use ,  keys to set the numeric data and unit.
- Press  to return to the main menu.
- Press  to confirm and save the numeric data.

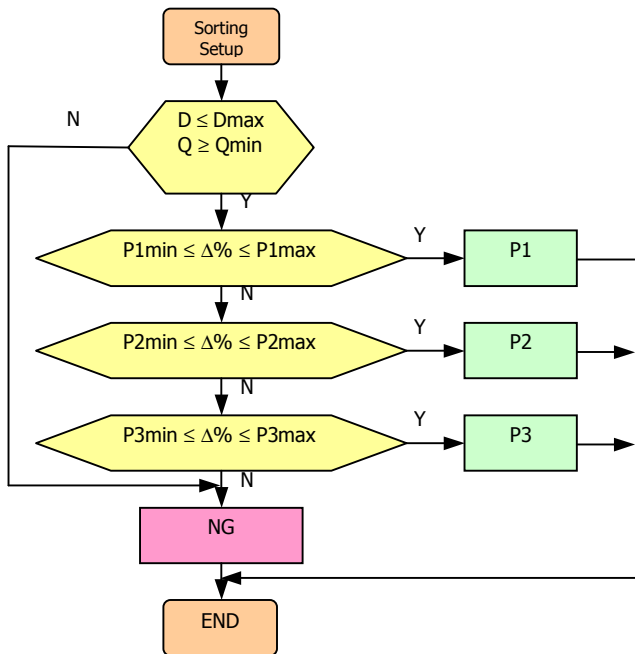







Figure 4-8 Sorting Flow Chart



6. Other Functions:

- Press  key to select the second function, “SHIFT” will be lighted on the screen.
- Press  key, APO will be flashing on the screen. Current delay time is also displayed.
- Press  key to enter the auto power off function setup, current delay time flashes on the screen.
- Use ,  keys to select 5', 10', 20' or 30'.
- Press  key to confirm the current delay time and return to the main menu.



Note:

When an external DC adapter is used, APO function is disabled automatically.

- Use ,  keys to select “CAL” function.
- Press  key to enter the calibration function. This function is protected with password and is not available for users.

3.3 Battery Replacement



Note:

The instrument will not be started, when the battery is weakening. Replace the battery immediately.

- Loosen the three screws with suitable driver and remove the bottom cover.
- Replace the degraded battery with a new DC 9V battery.
- Model 1604, 006P or other equivalent battery must be

used. Alkaline battery is recommended.

- If the instrument is not in use for more than three months, if the external DC adapter is always be used, please take out the battery.
- Close the bottom cover. The degraded battery must be disposed of properly.

3.4 Clearing Instruction

To clean the instrument, use a soft cloth slightly dipped in water. Do not spray cleanser directly onto the instrument, since it may leak into the cabinet and cause damage. Do not use chemicals containing benzene, alcohol or aromatic hydrocarbons.

Appendix

Message Code Table:

clear	Clear: Correction
Open	Open: Open correction
short	Short: Short correction
P1~	P1 ⁻ : High limit of P1 Bin
P1_	P1 ₋ : Low limit of P1 Bin
Mg	NG: No-Good
Q_	Q ₋ : Low limit of quality factor
D~	D ₋ : High limit of dissipation factor
Std	Std: Standard value (Nominal value)
ApO	APO: Auto Power Off
Cal	CAL: Accuracy Calibration
Psd	PSD: Password
Alert	Alert
OM	ON
Off	OFF
pass	Pass
faIl	Fail
Quit	Quit

First Edition2007-7